

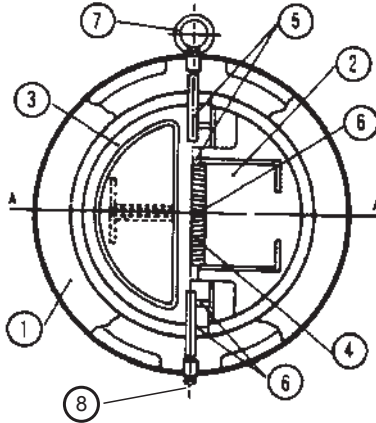

Cast iron body :  
stainless steel plate PN 16 DN 50 - 300 mm.



### Technical Characteristics

- Operates in any position : horizontal and vertical
- Minimum occupation of space
- For pumping, water supply, general industry
- Very low headloss

### Description

- Closing system : double plate with return springs

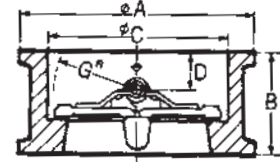

### Characteristics

Temperature IN °C	MIN.	-20°C	
	MAX. AT PEAK	+130°C at peak	+100 °C in Continuous
Pressure in bar	OPENING PRESSURE	Near 0	
	SERVICE	16	
	TESTING PRESSURE	25	
Mediums	Gas, Air, Water		
Headloss Chart	See Overleaf		
Connections	Mounting between PN 10-PN 16-ASA 150, Flanges DIN 2501-BS 4504		
Standards	Overall length as per NFE 29377 (face to face)		

### References - Dimensions - Performances

Ref.	DN	ØA mm		B mm		
		PN 10/16	ASA 150			
3000	3000 ASA	50	2	109	105	54
3001	3001 ASA	65	2 1/2	129	124	54
3002	3002 ASA	80	3	144	137	57
3003	3003	100	4	164		64
3004	3004	125	5	194		70
3005	3005	150	6	220		76
3006	3006	200	8	275		95
3007	3007	250	10	330		108
3008	3008	300	12	380		143

### Nomenclature

Nb	Description	Qty	Materials	Afnor	DIN	BS	ANSI
1	Casing	1	Cast Iron < 150 >200	FGL 250 FGS 400-15	GG 25 GGG 40	260 400	ASTM A 48 35 B ASTM A 536 60-40-18
2	Plate	2	Stainless Steel	Z7 CN 18.09	1.4301	304 S 31	304
3	Seat	1	NBR (nitrile)				
4	Spring	1*	Stainless Steel	Z7 CND 17.12.02	1.4401	316 S 19	316
5	Pins	2	Stainless Steel	Z7 CND 17.12.02	1.4401	316 S 19	316
6	Bearing	4	DN 50 to 125mm DN > 150 mm )	PTFE Polytetrafluorethylene			
7	Eye Bolt	1	DN > 200 mm				
8	Plugs	4	Brass	Cu Zn 40 Pb3	Cu Zn 39 Pb3	CZ 121 3Pb	ASTM 455

ØC mm	D mm	G mm	Weight	Kv	z
mm	mm	mm	kg	m³/h	
60	29	28	1.2	39.5	6.30
73	29	35	1.8	82.5	4.10
89	27	42	2.9	137.0	3.40
114	30	54	3.9	250.0	2.50
141	31	67	5.8	513.0	1.45
168	32	81	8.0	891.0	1.00
219	41	103	14.0	1503.0	1.10
273	48	131	22.0	2746.0	1.10
324	66	154	34.0	3986.0	1.10

\* 2 from DN 150

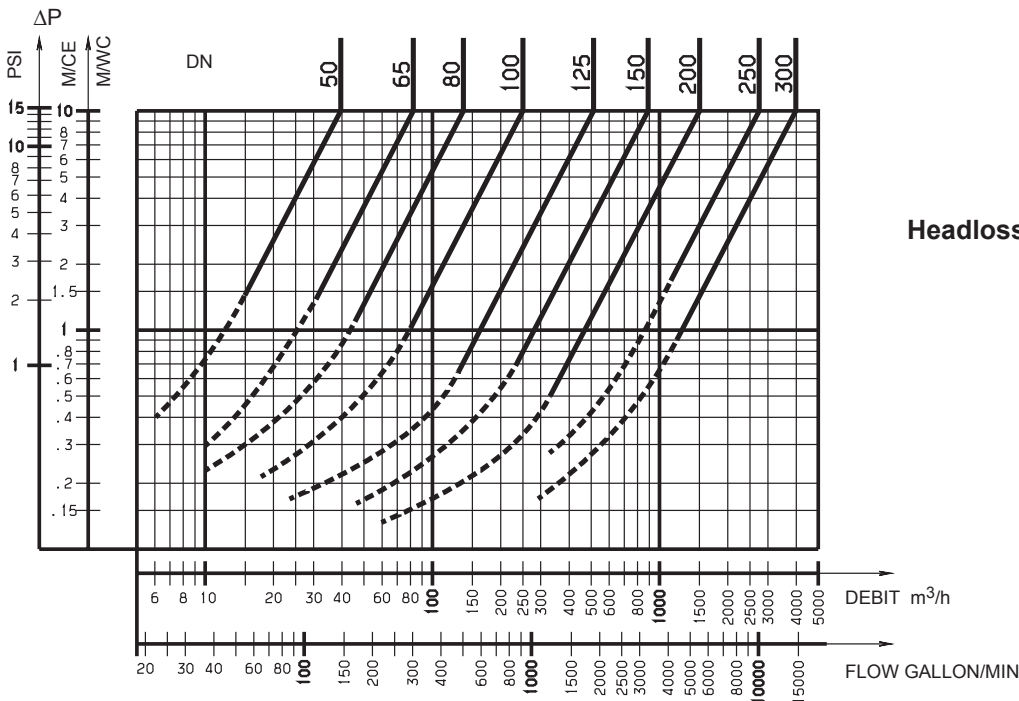

Headloss Chart

\*last updated 03/16

