

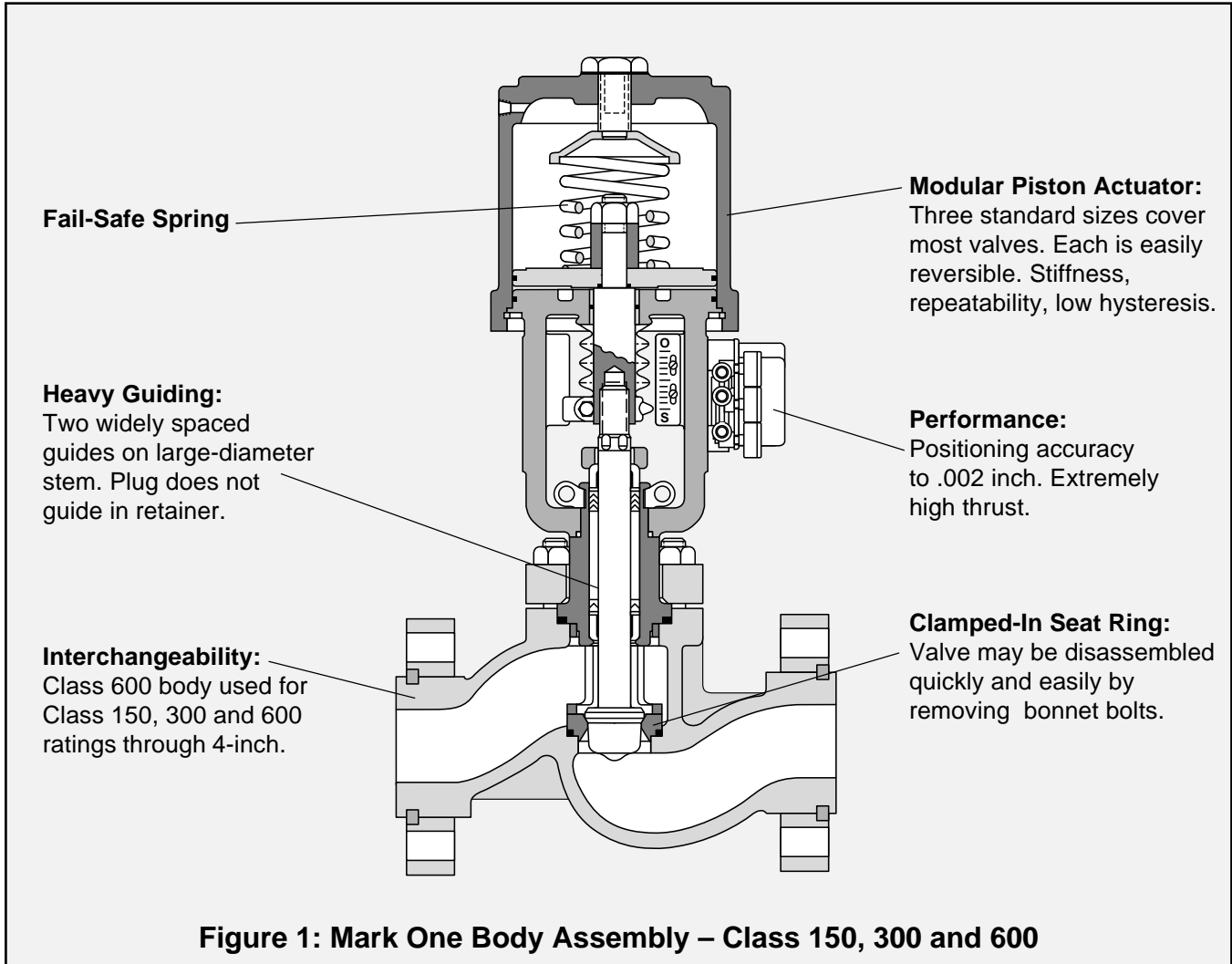

*Valtek Mark One
Control Valves*

Valtek Mark One Body Assembly



The Valtek® Mark One™ globe control valve offers superior performance in liquid and gaseous services, while also permitting easy, fast and inexpensive maintenance.

Unlike diaphragm-operated control valves, the spring-cylinder actuated Mark One provides stiffness and maintains high positioning accuracy, repeatability, controlled high speed and faithful response. The Mark One handles up to 150 psig / 10.3 Barg supply air and has the thrust to shut off against much higher fluid pressures.

Most diaphragm actuators rely entirely on springs to close the valve, but the Valtek Mark One is designed so the spring, supply air pressure and fluid pressure itself combine to produce exceptionally tight shutoff. A self-aligning seat ring further enhances the shutoff capability of the Mark One.

Many globe valve maintenance problems can be traced to cage-guiding. The close metal-to-metal contact between the cage and plug often result in galling and sticking. The Mark One, however, is double top-stem guided and completely avoids contact between the plug and seat retainer.

The clamped-in seat and top-entry trim permits easy, quick maintenance. Plus, with Mark One's high degree of parts interchangeability, fewer inventory parts are required. In addition, the actuator is lighter, smaller and easier to handle than comparable diaphragm actuators.

The Valtek Mark One is the industry choice for a simple, reliable, tough globe valve.

Valtek Mark One Advantages and Features

Advantages	Features
Reliable, predictable service	Stiff, high-thrust cylinder actuator Accurate positioning High repeatability Faithful response Controlled, high-speed stroking action
Won't stick and shut down	Cage guiding eliminated Double stem guiding located out of flow stream Generous clearance between plug head and seat retainer
Easy, fast and inexpensive	Top-entry servicing Clamped-in seat ring Evenly compressed gasket – controlled gasket compression Separable flanges High degree of parts interchangeability Small, lightweight design
Leakproof when closed	High-thrust, spring-cylinder actuator Self-aligning seat ring Assisted shutoff from fluid pressure, cylinder spring, cylinder pressure Spring fails valve to desired position, pneumatics provide additional force
Built for toughest service	Corrosion-resistant construction High thrust overcomes high pressures Anti-cavitation and noise-trim options Heavy-duty plug stem Factory mutual approved as a fuel service valve (³ / ₄ - 3-inch)
Compact and easy to install	Cylinder actuator is smaller than comparable diaphragm actuators Lower center of gravity than comparable diaphragm actuators Light weight means less pipe stress from static and dynamic loads Separable end flanges allow the valve to be installed in many orientations and compensate for flange misalignment
Design provides lower total lifetime cost	High interchangeability between sizes and other Valtek control products Valve design minimizes requirements for stocking spare parts Rugged, heavy-duty parts provide extended life Actuator design allows simple, easy maintenance

Valtek Mark One Components

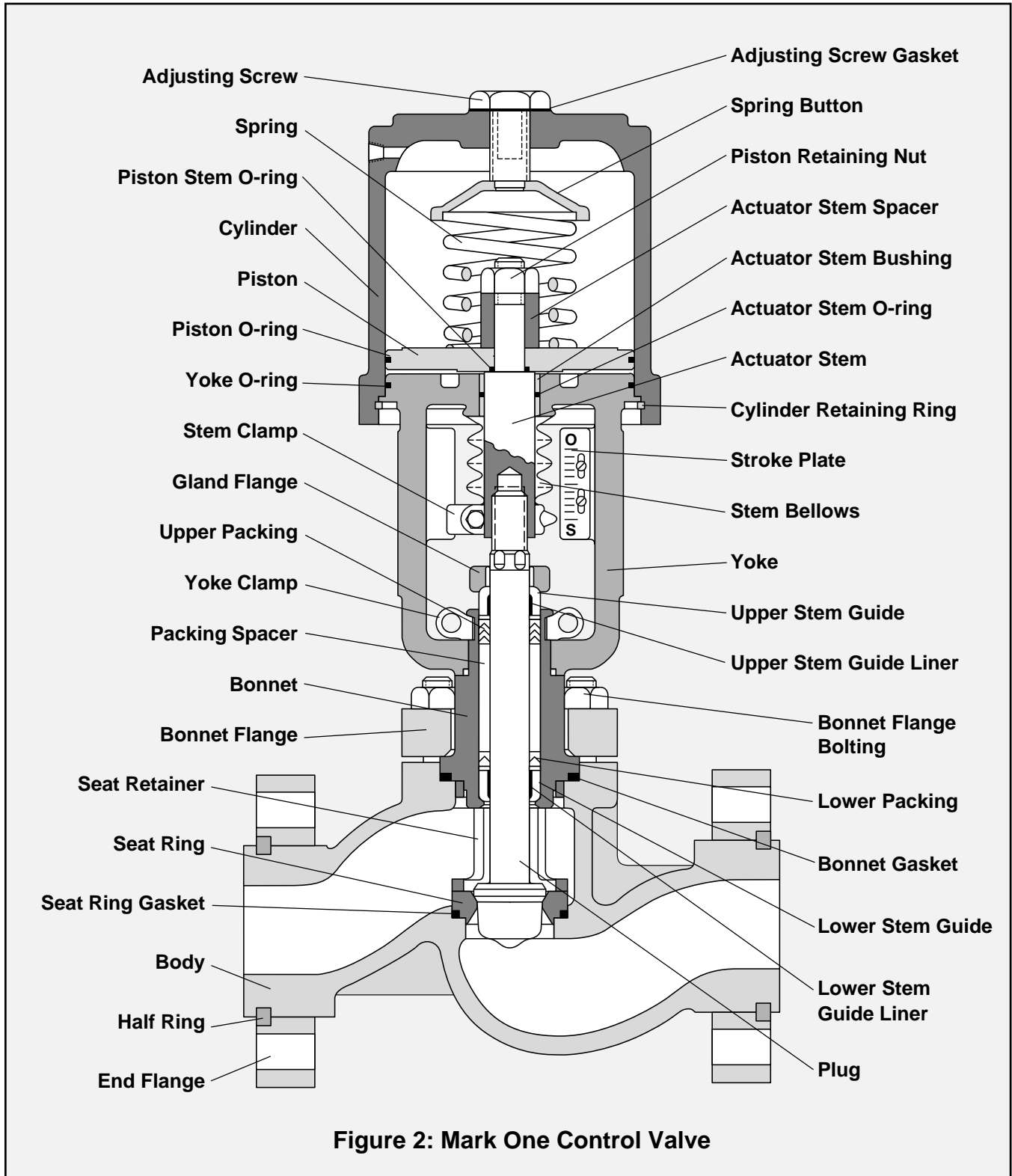

Valtek Mark One Body Styles

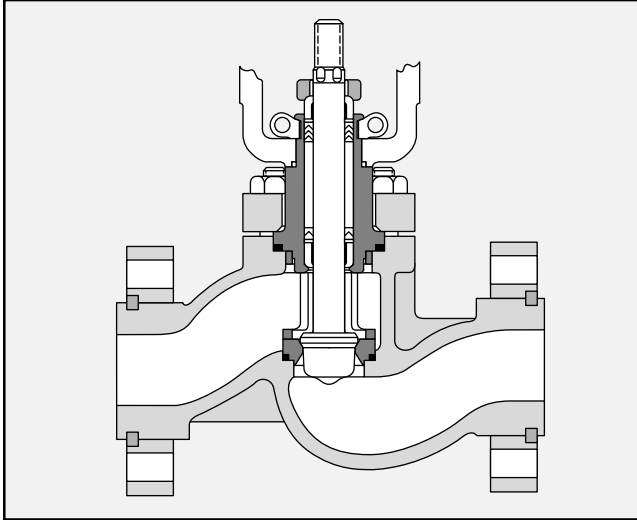

Figure 3: Globe-style Body

Globe-style bodies feature smooth, streamlined, constant-area internal passages with no pockets, permitting high capacity with minimum turbulence. They are designed with nearly constant wall thickness, providing lower weight and cost when manufactured in expensive stainless or alloy steels.

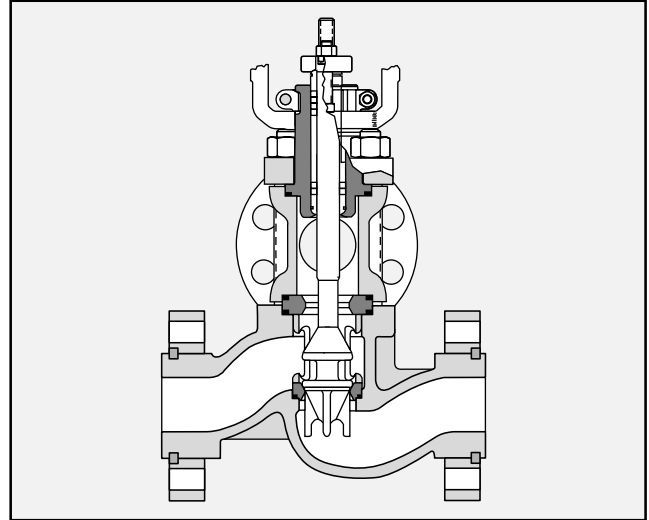

Figure 4: Three-way Body

Three-way bodies are used for either combining or diverting services. Due to Flowserve's excellent parts interchangeability, a standard globe valve easily converts to three-way service with the addition of a three-way adaptor, upper seat ring, two gaskets, three-way plug and longer bonnet flange studs.

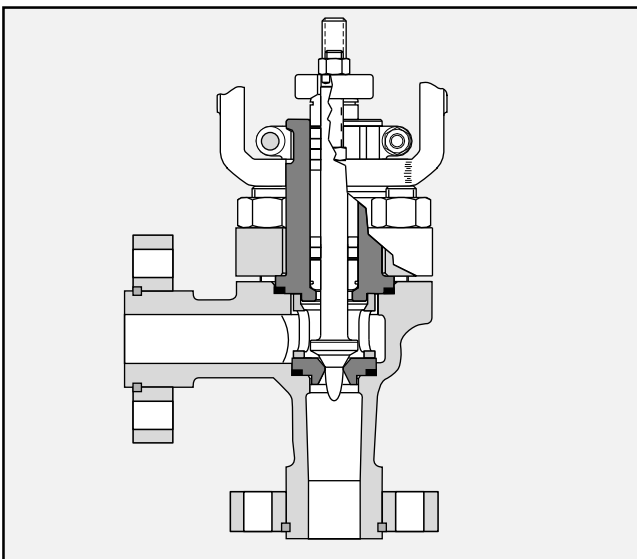

Figure 5: Angle-style Body

Except for the body and 1½-inch seat ring, the angle-style Mark One is completely interchangeable with the globe style – all other valve parts remain the same. For additional body protection, a venturi seat ring, extending to the outlet flange, is available.

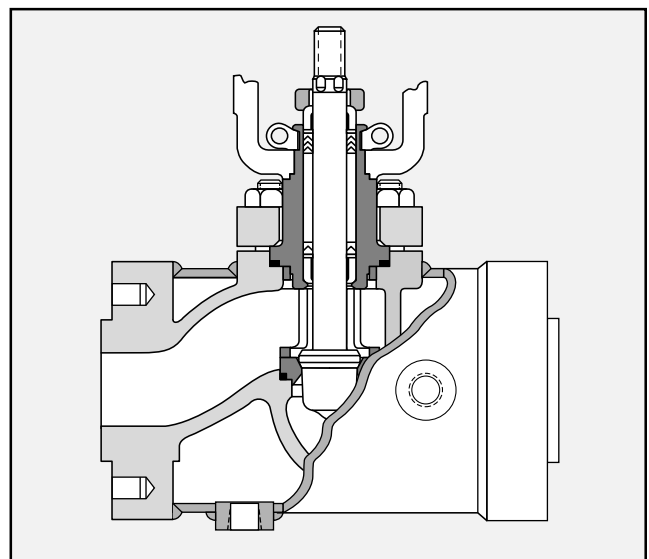

Figure 6: Steam-jacketed Body

The steam-jacketed Mark One uses a standard globe style body with oversized, blind flanges for a full jacket or standard flanges for a partial jacket. The jacket is rated for 150 psig / 10.3 Barg and is equipped with a ¾-inch NPT supply and drain connection.

Valtek Mark One End Connections, Flanges and Bolting

Mark One body facings come standard as raised face for either separable and integral flanges. To achieve better sealing with mating piping, the flange face is machined with spiral grooved serration. Other optional facings include smooth face, flat face, ring joint, large and small tongue, and large and small groove.

Separable End Flanges

Interchangeable separable flanges are standard for valve bodies 1/2-through 4-inch in class 150, 300 and 600 ANSI ratings, and for 6- and 8-inch bodies in Class 300 and 600. With separable end flanges, a class 600 body can be adapted for Class 150, 300 or 600 service by simply changing the end flanges.

Separable flanges are usually furnished in carbon steel for maximum cost savings, although stainless steel can be specified if needed.

Bonnet Flange

The bonnet flange incorporates the same separable design as the end flanges and is normally manufactured in carbon steel; however, it can be specified in stainless steel when required.

Bonnet Flange Bolting

All sizes use studs and nuts that are furnished in 304 and 316 stainless steel, suitable for -423° to 1500° F / -253° to 816° C. These temperature limits are for maximum pressure permitted by ANSI B16.34, 1988.

Table 1: End Connections

End Connection	Valve Size (inches)	Class	Standard Face-to-Face	Optional Face-to-Face
Separable Flange	1/2 - 4	150 - 600	ANSI (a)	ISA
	6 - 8	300 - 600	ISA (b)	
Integral Flange – Steel & Alloys	1/2 - 48	150	ISA	
	1/2 - 48	300 - 600	ISA	
	1/2 - 24	900 - 2500	ISA (c)	
Screwed	1/2 - 2	150 - 600	ANSI	
	1/2 - 2	900 - 2500	ISA (c)	
Socketweld	1/2 - 2	150 - 600	ANSI	ISA
	1/2 - 2	900 - 2500	ISA (c)	
Buttweld	1/2 - 4	150 - 600	ANSI	ISA
	6 - 36	150 - 600	ISA	
	1/2 - 24	900 - 2500	ISA (c)	

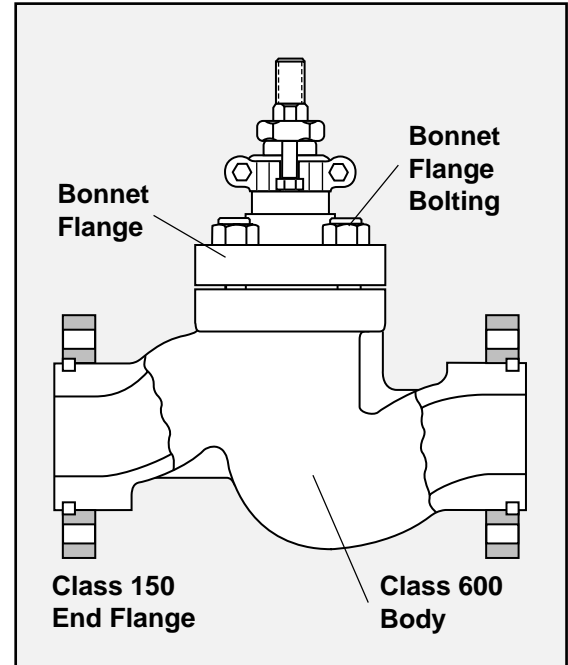

**Figure 7:
Separable End and Bonnet Flanges**

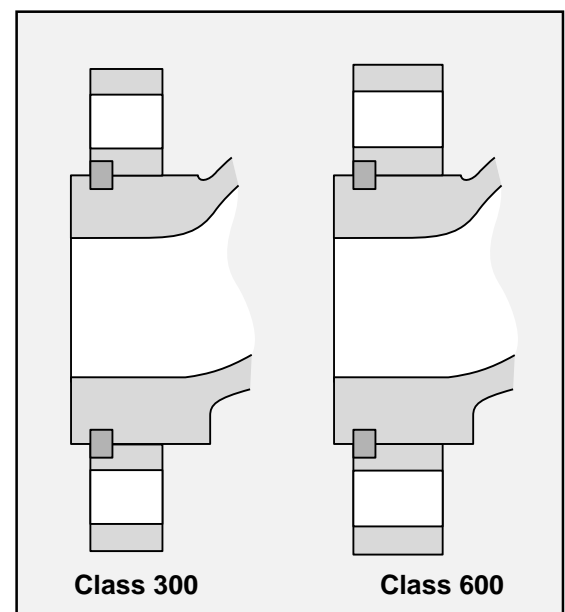

Figure 8: End Flanges

- (a) ANSI B16.10 Class 600 globe valves
 (b) ANSI/ISA S75.03, 1985
 (c) See Table 20

Valtek Mark One Gaskets and Clamps

The Mark One is designed with the bonnet and seat ring gaskets fully retained. Since the bonnet bottoms metal-to-metal in the body, the bonnet gasket compression is determined by the depth of the gasket step on the bonnet, which is machined to provide the required gasket compression.

When the bonnet is fully installed, force is transmitted through the seat retainer to secure the seat ring in position. The body, seat retainer and seat ring are all machined to close tolerances to provide the proper gasket compression. Unlike the bonnet, the seat ring does not bottom in the body, allowing this small clearance to compensate for manufacturing tolerances and thermal expansion.

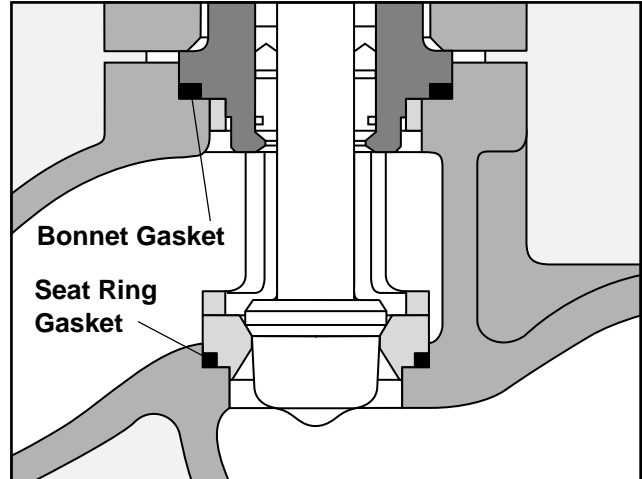

Figure 9: Body Gaskets

Table 2: Gasket Specifications

	Type	Gasket Material	Maximum Gasket Temp. °F / °C	Minimum Gasket Temp. °F / °C
Standard Gaskets	Flat	Teflon (TFE)	350 / 177	-200 / -130
	Spiral Wound	304 S.S./AFG	750 / 400	-20 / -30
	Spiral Wound	316 S.S./AFG	1000 / 538	-20 / -30
Alternate Gaskets	Flat	AFG	600 / 318	-20 / -30
	Flat	KEL-F	350 / 177	-320* / -196*
	Flat	Teflon (FEP)	400 / 204	-320 / -196
	Flat	Grafoil**	1500** / 816**	-320 / -196
	Spiral Wound	316 S.S./Grafoil**	1500** / 816**	-320 / -196
	Hollow O-ring	Inconel X-750	1500 / 816	-20* / -30*

*Lower temperature available upon request.

**Limited to 800° F / 427° C for oxidizing service.

Yoke Clamps

The actuator is typically attached to the Mark One body assembly with two precision-cast, stainless steel yoke clamps. In some cases, however, the actuator is bolted directly to the bonnet. Each clamp has an inclined plane surface which, when bolted together, securely fastens the actuator yoke to the bonnet. Unlike conventional threaded clamps, the Flowserve clamp design permits easy removal even under extremely corrosive conditions.

Associated bolts and locknuts are supplied in plated carbon steel, although stainless steel is also available when required.

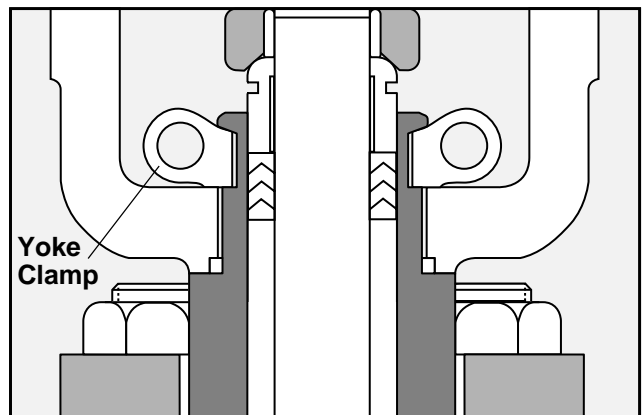

Figure 10: Yoke Clamp

Valtek Mark One Bonnet Types

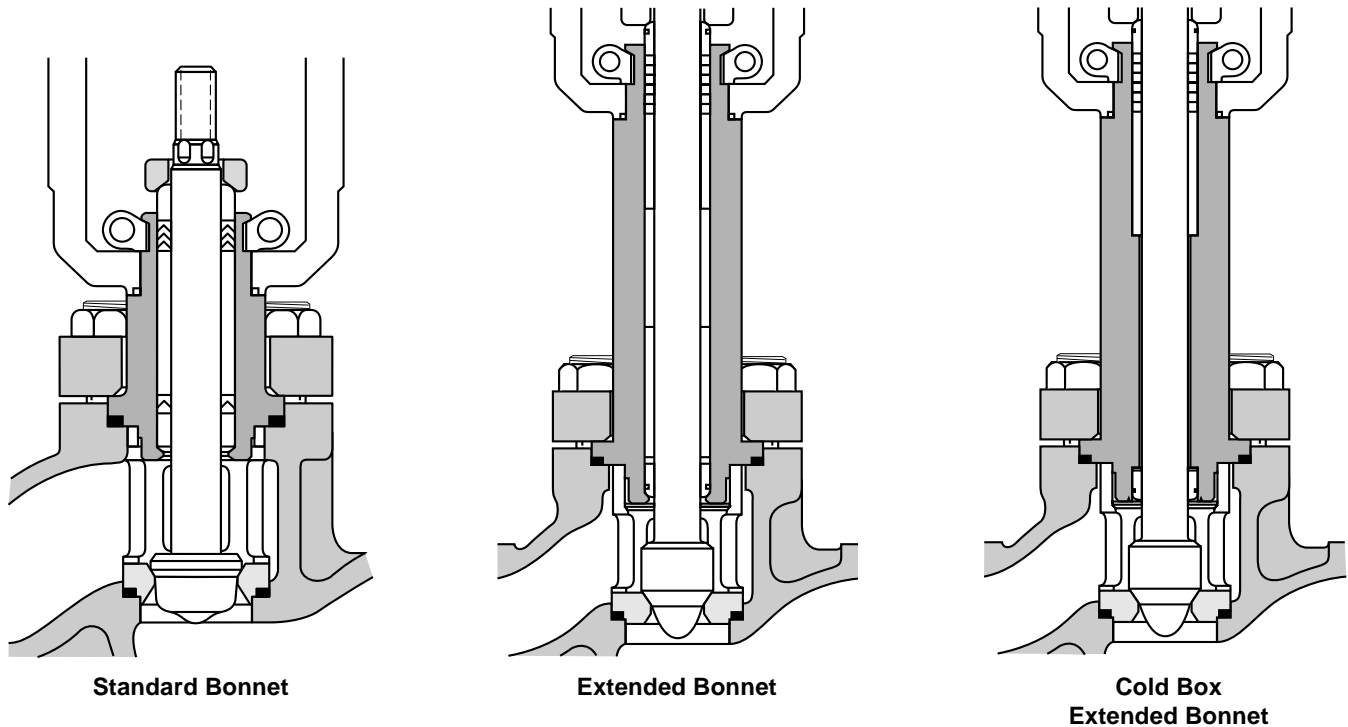

Figure 11: Mark One Bonnet Types

Standard Bonnet

The Mark One bonnet is usually constructed of the same material as the body and handles temperatures from -20° to 750° F / -30° to 400° C (See table 4 on page 9 for packing limitations.)

Extended Bonnet

The extended bonnet protects the packing from excessive heat or cold, which may inhibit valve performance. The bonnet is constructed of carbon steel for temperatures from -20° to 800° F / -30° to 427° C and of 304 or 316 stainless steel for -150° to 1500° F / -100° to 816° C.

Cold Box Extended Bonnet

The cold box extended bonnet permits stagnated, moderate temperature gas to form in the bonnet, which protecting the packing from the service fluid. Typically manufactured from 304 or 316 stainless steel, it handles temperatures down to -423° F / -253° C. Standard construction consists of stainless steel bonnet flange and bolting.

Guardian II Formed Metal Bellows Seal Bonnet

The Guardian II formed metal bellows seal can be used whenever service fluid leakage to atmosphere needs to be reduced to an absolute minimum. The standard metal bellows seal is rated for operation in processes ranging in temperature from -320° F to 1100° F / -196° to 593° C and pressures to 1100 psig / 75.9 Barg.

The flexible metal bellows is typically constructed of Inconel 625 and is also available in Hastelloy C-22. The Guardian II bellows seal allows for outside pressure to minimize bellows squirm, prolonging bellows life.

Guardian Metal Bellows Seal Bonnet

The Guardian metal bellows seal provides protection against unwanted packing leakage to atmosphere in processes involving caustic liquids or gases.

The compact, lightweight design of the Guardian makes it ideal for services less than 650° F / 343° C and 310 psig / 21.4 Barg. The precision-formed bellows is available in Inconel or Hastelloy C materials.

Bellows seals are designed for special service conditions and not to valve's design class; therefore, complete and accurate service conditions must be specified.

Valtek Mark One Packing and Guiding

Packing Box

The standard Valtek packing boxes are deeper than most conventional types, providing the following advantages:

1. The spacing between the wiper set and the main, upper packing set prevents contamination of the upper packing. The upper set is positioned far enough away from the wiper set to avoid contact with any part of the plug stem that has been exposed to the flowing medium. The wiper set is designed to minimize the amount of fluid on the plug stem.
2. Bonnets are designed to permit a wide variety of packing configurations, including a double set of packing, without changing bonnets.
3. Two widely spaced stem guides, when used with the Mark One's large plug stem diameter, provide exceptional guiding. The upper stem guide also acts as a packing follower; the lower guide is situated close to the plug head for additional guiding support, ensuring accurate alignment of plug and seat ring.
4. Grafoil-lined stainless steel guides provide superior guiding over wide temperature ranges and completely eliminate guide/stem galling. A variety of guides are available for various applications, including solid brass, Stellite and glass-filled Teflon-lined stainless steel.

Table 3: Guides

Standard Materials	Max. Temp.	Min. Temp.	Maximum Pressure
Grafoil lined SS***	1500°F / 816° C	-320°F / -196° C	1400 psig / 96.6 Barg thru 2-inch 1000 psig / 69.0 Barg 3 thru 4-inch 850 psig / 58.6 Barg 6-inch & up
Glass-filled			150 psig / 10.3 Barg @ 100° F / 38° C
Teflon-lined S.S.	350° F / 177° C	-423° F / -253° C	100 psig / 6.9 Barg @ 350° F / 177° C
Solid Bronze	500° F / 260° C	-423° F / -253° C	Same as body
Solid Stellite	1500° F / 816° C	-423° F / -253° C	Same as body

Table 4: Packing

Bonnet Type	Packing Material	Service Fluid Temperature Limitation ° F / ° C
Standard** Bonnet	Teflon, Teflon/AFP and Glass-filled Teflon	500 / 260
	Graphite/AFP	750 / 400
	Graphite/AFP, Inconel wire	750* / 400*
	Grafoil***	750* / 400*
Extended** Bonnet	Teflon, Teflon/AFP and Glass-filled Teflon	600 / 316
	Graphite/AFP	1200 / 650
	Graphite/AFP, Inconel wire	1200 / 650
	Grafoil***	1500 / 816
Cryogenic Extended Length**		
15-, 18-inch	Teflon	-320 / -196
24-, 27-inch	Teflon	-423 / -253

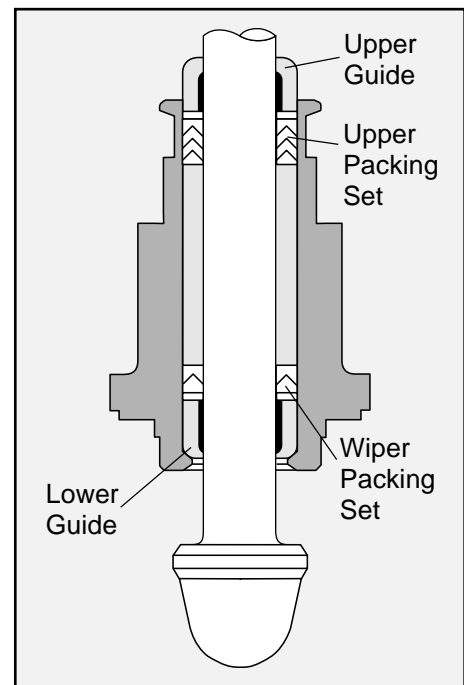

Figure 12: Typical Teflon V-ring Arrangement

* Temperatures assume environmental temperature is less than 90° F / 32° C; 8 through 12-inch Class 150 through 600 and 3 through 12-inch Class 900-2500 handles temperatures to 850° F / 454° C.

** ANSI B16.34 specifies acceptable pressure temperature limits for pressure retaining materials. Consult the factory for additional information.

*** Do not use Grafoil above 800° F / 427° C in oxidizing service such as air or oxygen. The use of Grafoil packing may require oversize actuators or heavier springs due to added friction.

Valtek Mark One Flow Characteristics, Trim Types

Equal Percentage

Equal percentage is the characteristic most commonly used in process control. The change in flow per unit of valve stroke is directly proportional to the flow occurring just before the change is made. While the flow characteristic of the valve may be equal percentage, most control loops produce an installed characteristic, which approaches linear when the overall system pressure drop is large relative to that across the valve.

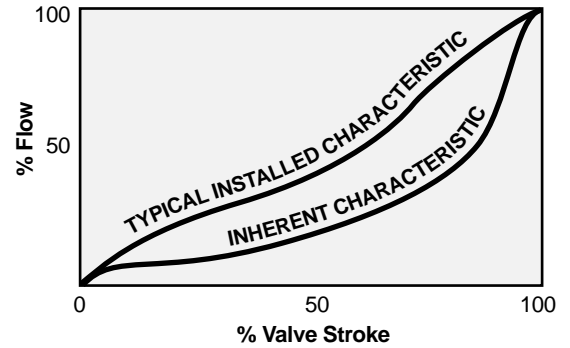
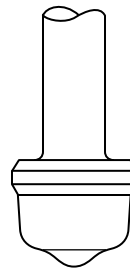

Linear

Linear inherent characteristic produces equal changes in flow per unit of valve stroke regardless of plug position. Linear plugs are used on those systems where the valve pressure drop is a major portion of the total system pressure drop.

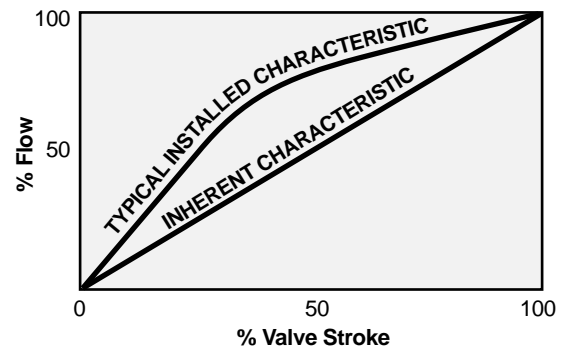
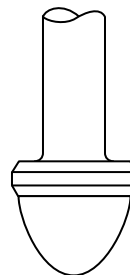

Quick Open

Quick open plugs are used for on-off service and are primarily designed to produce maximum flow quickly.

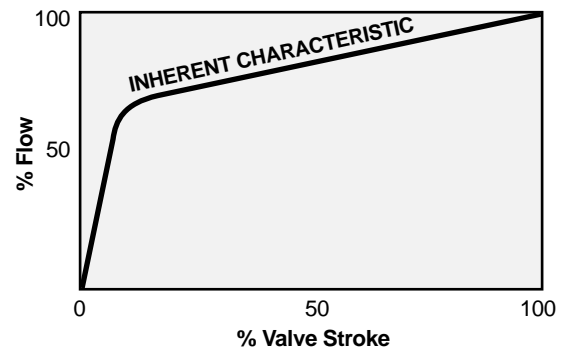
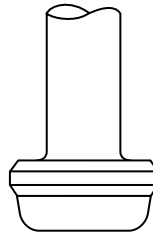

Figure 13: Flow Characteristics

Trim Types

Three trim types are available. Standard full-area trim provides maximum C_v . Reduced trim is available in a wide variety of sizes when lower C_v values and large bodies are required. Integral trim uses a special seat machined into the body and an oversized plug to provide additional C_v beyond the capabilities of full-area trim.

Mark One valves can be converted from one trim type to another since all seat rings and plugs with a given size and pressure class are completely interchangeable. Integral trim is available by removing the seat ring and by changing the plug.

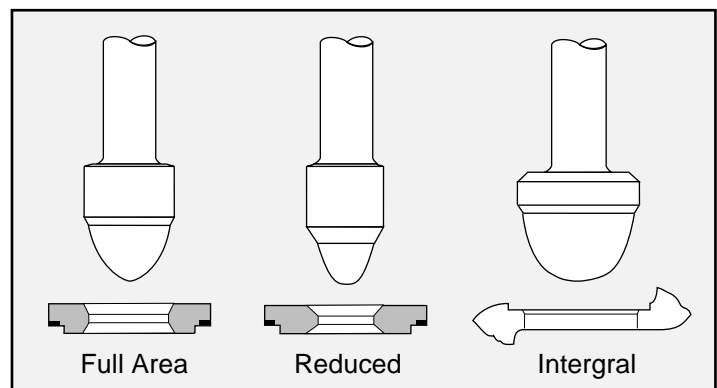

Figure 14: Typical Trim Types

Valtek Mark One Standard Trim, Pressure-balanced Trim

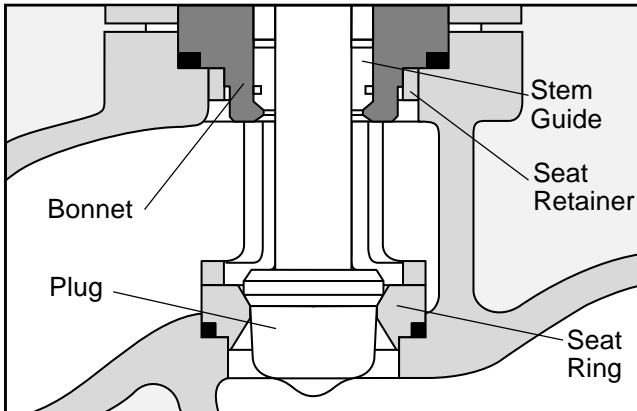

Figure 15: Standard Trim

Mark One trim is designed to avoid the difficulties associated with screwed-in seats and cage-guiding. The seat ring is clamped into the body by the bonnet and seat retainer; thus, removal of the seat is easy even under extremely corrosive conditions.

Unlike cage-guided trims that easily gall and stick, Mark One plugs are double-stem guided, avoiding contact between the seat retainer and plug. Because no contact is made with the plug, the retainer can be constructed of stainless steel rather than costly hard materials. The flow characteristic is determined by the plug contour, rather than by the opening in the retainer.

Low-noise seat designs have been developed for better noise control in standard Mark One valves.

Metal Seats

Metal seated valves handle Class IV shutoff (ANSI B16.104, 1976 – FCI 70-2). This class calls for maximum permissible seat leakage of 0.01 percent of rated valve capacity. All Valtek control valves are seat-leak tested after assembly and are substantially lower in leakage than called for by this class. This exceptional seat tightness is obtained by aligning the seat ring with the plug during assembly. Additional seat tightness using metal seats is available as an option.

Table 5: Standard Seal Temperature Ranges

Teflon Sleeve	-320° F / -196° C @ full rating or 300° F / 150° C @ 150 psig / 10.3 Barg
NiResist Piston Rings	-20° to 800° F / -30° to 427° C
Buna-N O-ring	-60° to 250° F / -51° to 121° C
Rene 41	800° to 1600° F / 427° to 871° C
Spring energized TFE	-365° to 575° F / -221° to 302° C
Viton	-40° to 437° F / -40° to 225° C

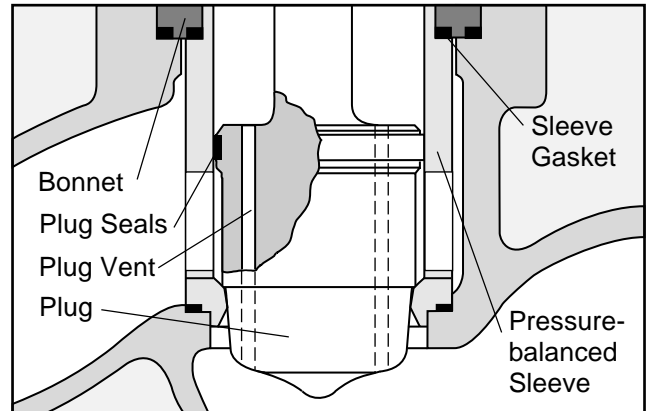

Figure 16: Pressure-balanced Trim

In high pressure drop applications, pressure-balanced trim is used to reduce the thrust necessary to stroke the plug by reducing the trim off-balance area. Because the pressure-balanced plug fits closely to the retainer, this trim should only be used in generally clean services.

Flow direction is under the plug for fail-closed and over the plug for fail-open. The seal area less the stem area is designed to be slightly larger than the seat area; therefore, the plug is off-balanced to close for flow under the seat and off-balanced to open for flow over the seat.

Soft Seats

The Mark One soft seat is used in applications requiring ANSI Class VI “bubble-tight” shutoff. Its design consists of an elastomer sandwiched between two metal pieces. The assembled soft seat is interchangeable with the hard seat for a given size and pressure rating. Inserts are often constructed of Teflon, therefore, maximum temperature should be below 300° F / 150° C at 290 psig / 20 Barg. For temperatures below -85° F / -65° C, Teflon soft seats can be used in high-pressure applications.

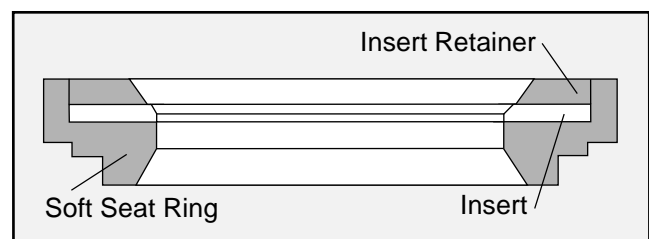

Figure 17: Typical Soft Seat Configuration

Valtek Mark One Trim Materials, Data

Standard plug and seat ring material is 316 stainless steel, except special alloy bodies where trims are furnished in the same material as the body. A wide variety of services are successfully handled by stainless steel trim parts. Nevertheless, a general rule is to consider hard trim for all choked flow conditions or for temperatures above 600°F / 316°C. Stellite No. 6 is stocked for many valve trim parts. This material offers a good combination of relative hardness and corrosion resistance. Special alloys, such as Alloy 20, Hastelloy C and Monel, are also available.

Table 6: Material Hardness Ratings

Trim Material	Hardness Rockwell C	Corrosion* Resistance
316 S.S.	8	Excellent
Stellite No. 6	44	Good to Excellent
416 S.S.	40	Fair
440C S.S.	56	Fair
17-4 PH	40	Excellent
Colmonoy	45-50	Fair to Good
Tungsten Carbide	72	Good on Bases Poor on Acids

* General rule only. Check specific application.

Table 7: Standard Unbalanced Valve/Actuator Data

Valve Size (inches)	Rating Class	Full Area Trim Size	Seat Area (sq. in.)	Stem Dia.	Stem Area (sq. in.)	Std. Act. Size*	Stroke (inches)
1/2	150-600	.50	.196	.562	.248	25	.75
3/4	150-2500	.72	.405	.562	.248	25	.75
1	150-600	.81	.518	.562	.248	25	.75
1	900-1500	.81	.518	.562	.248	25	.75
1	2500	.72	.405	.562	.248	25	.75
1 1/2	150-600	1.25	1.23	.875	.601	25	1.00
1 1/2	900-1500	1.25	1.23	.875	.601	50	1.00
1 1/2	2500	1.00	.785	.875	.601	50	.75
2	150-600	1.62	2.07	.875	.601	25	1.50
2	900-1500	1.62	2.07	.875	.601	50	1.50
2	2500	1.25	1.23	.875	.601	50	1.00
3	150-600	2.62	5.41	1.125	.99	50	2.00
3	900-1500	2.62	5.41	1.5	1.77	100	2.00
3	2500	2.00	3.14	1.125	.99	100	1.50
4	150-600	3.50	9.62	1.125	.99	50	2.50
4	900-1500	3.50	9.62	1.5	1.77	100	2.50
4	2500	2.62	5.41	1.5	1.77	100	2.00
6	150	5.00	19.63	1.125	.99	50	3.00
6	300-1500	5.00	19.63	2.0	3.14	100	3.00
6	2500	4.00	12.57	2.0	3.14	100	3.00
8	150	6.25	30.68	1.5	1.77	100	4.00
8	300-600	6.25	30.68	2.0	3.14	100	4.00
8	900-1500	6.25	30.68	2.5	4.91	100	4.00
8	2500	5.00	19.63	2.5	4.91	100	3.00
10	150	8.75	60.13	2.0	3.14	100	4.00
10	300-600	8.75	60.13	2.5	4.91	100	4.00
10	900-1500	8.00	50.27	3.0	7.07	100	4.00
10	2500	6.25	30.68	3.0	7.07	100	4.00
12	150	9.50	70.88	2.0	3.14	100	4.00
12	300-600	9.50	70.88	3.0	7.07	100	4.00
12	900-2500	8.00	50.27	3.0	7.07	100	4.00
14	150	11.00	95.03	3.0	7.07	100	4.00
14	300-600	11.00	95.03	3.0	7.07	100	4.00

* Minimum standard actuator size. Oversized actuators may be required for large pressure drops.

Valtek Mark One

Trim Data, Hard Facing

TABLE 8: Standard Pressure-balanced Valve / Actuator Data (inches)

Valve Size (inches)	Rating Class	Full Area Trim Size*	Seat Area (sq. in.)	Stem Dia. (sq. in.)	Stem Area (sq. in.)	Sleeve Area (sq. in.)	Off-balance Area sq. in.		Standard Actuator Size**	Stroke (inches)
							Flow under To Close	Flow over To Open		
2	600	1.62	2.07	.562	.248	2.58	.26	.51	25	1
2	1500	1.62	2.07	.562	.248	2.41	.09	.34	50	1
2	2500	1.25	1.23	.562	.248	1.55	.07	.32	50	1
3	600	2.62	5.41	.875	.601	6.77	.76	1.36	50	1.5
3	1500	2.62	5.41	.875	.601	6.49	.48	1.08	100	2
3	2500	2.0	3.14	.875	.601	3.86	.12	.72	100	1.5
4	600	3.5	9.62	.875	.601	11.41	1.19	1.79	50	2
4	1500	3.5	9.62	1.125	.994	11.41	.80	1.79	100	2
4	2500	2.62	5.41	1.125	.994	6.77	.37	1.36	100	2
6	150	5.0	19.63	1.125	.994	22.69	2.06	3.06	50	2.5
6	600	5.0	19.63	1.5	1.77	23.76	2.36	4.13	100	2.5
6	1500	5.0	19.63	1.5	1.77	22.69	1.29	3.06	100	2.5
6	2500	4.0	12.57	1.5	1.77	15.03	.69	2.46	100	2.5
8	600	6.25	30.68	1.5	1.77	35.78	3.33	5.10	100	3
8	1500	6.25	30.68	2.0	3.14	35.78	1.96	5.10	100	4
8	2500	5.0	19.63	2.0	3.14	23.76	.99	4.13	100	3
10	600	8.0	50.27	2.0	3.14	58.36	4.95	8.09	100	3
10	1500	8.0	50.27	2.5	4.91	58.36	3.18	8.09	100	4
10	2500	6.25	30.68	2.5	4.91	37.12	1.53	6.44	100	4
12	600	9.5	70.88	2.5	4.91	82.52	6.73	11.64	100	4
12	1500	9.5	70.88	2.5	4.91	79.53	3.74	8.65	100	4
12	2500	8.0	50.27	2.5	4.91	56.75	1.57	6.48	100	4
14	150	11.0	95.03	2.5	4.91	108.43	8.49	13.40	100	8
14	600	11.0	95.03	3.0	7.07	106.05	3.95	11.02	100	8
14	1500	11.0	95.03	3.0	7.07	103.87	1.77	8.84	100	8
16	600	12.75	127.68	3.0	7.07	148.49	13.74	20.81	100	8
16	1500	12.75	127.68	3.0	7.07	140.61	5.86	12.93	100	8

* This data does not apply to ChannelStream or MegaStream trim.

** Minimum standard actuator size. Oversized actuators may be required for large pressure drops.

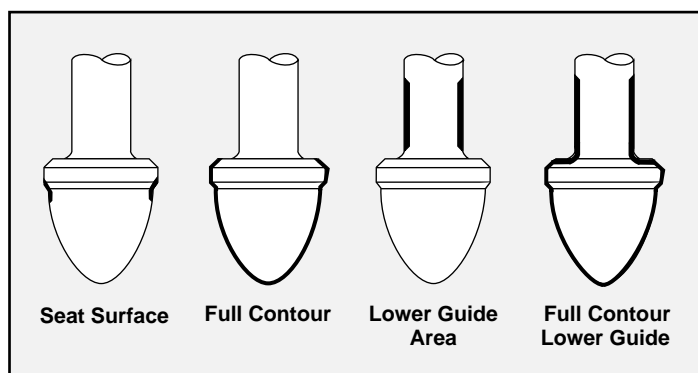
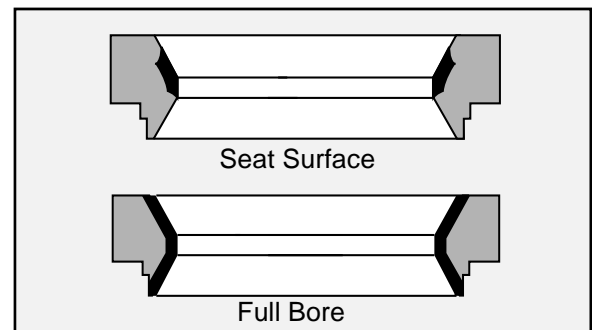
Figure 18: Hard Facing Variations – Plug

Figure 19: Hard Facing Variations – Seat

C_v Data

See Sizing & Selection, Section 4 for flow coefficients (C_v values) according to trim characteristic, body rating, and flow direction.

Valtek Mark One

Standard Materials of Construction, Estimated Shipping Weights

Table 9: Body Materials

Sizes	1/2 – 48 inch; class 150 thru 600 1/2 – 24 inch; class 900 thru 2500 1/2 – 12 inch; class 4500
Forms	Globe, angle, three-way
ANSI Ratings	Class 150, 300, 600, 900, 1500, 2500
Materials	Carbon steel, stainless steel, Monel, nickel, chrome-moly, Titanium, Alloy 20, bronze, Hastelloy B, Hastelloy C, other castable materials
End Connections	Separable flange: 1/2 – 4 inch, class 150 thru 600 6 – 8 inch, class 300 and 600 Integral flange: all sizes NPT: 1/2 – 4 inch Socketweld: 1/2 – 4 inch Grayloc: all sizes
Separable End Flange Material	Carbon steel, 316 stainless steel; other material as required

Table 10: Bonnet Materials

Types	Standard, standard extension, special length extension, bellows seal, cryogenic
Flange	Separable
Materials	Bonnet: same as body Bellows: stainless steel, other materials as required Bellows Housing: carbon steel, 316 stainless steel, other materials as required Bonnet flange: carbon steel, 316 stainless steel, other material as required

Name plate

Valves are equipped with stainless steel name plates. An example is illustrated below.

Flowserve Corporation	
CLASS _____	S/N _____ MARK _____ SIZE _____
○ AIR TO _____	T/N _____ Cv _____ CHAR _____
BODY _____	SIGNAL _____ TRIM _____
TAG _____	
P.O. _____	

Table 11: Estimated Shipping Weights
Globe, Flanged Valves with Cylinder Actuators and Positioners

Size (in.)	Weight in Pounds / Kilograms						Add for Extended Bonnet
	Class 150	Class 300	Class 600	Class 900	Class 1500	Class 2500	
1/2 - 3/4	40 / 18	40 / 18	40 / 18				5 / 2
1	50 / 23	50 / 23	50 / 23	100 / 45	120 / 54	150 / 68	5 / 2
1 1/2	65 / 30	65 / 30	65 / 30	170 / 77	180 / 82	210 / 95	5 / 2
2	75 / 34	75 / 34	75 / 34	200 / 91	220 / 100	300 / 136	5 / 2
3	160 / 73	170 / 77	180 / 82	400 / 182	430 / 195	500 / 227	15 / 7
4	240 / 109	250 / 114	265 / 120	590 / 268	610 / 277	940 / 427	20 / 9
6	360 / 163	570 / 259	600 / 272	1000 / 454	1170 / 531	1400 / 636	40 / 18
8	590 / 268	790 / 359	830 / 377	1100 / 499	1320 / 599	1740 / 790	65 / 30
10	1050 / 477	1405 / 638	1600 / 726	2050 / 931	2200 / 999	2600 / 1180	90 / 41

Part Identification

Nearly every part on a Valtek control valve has an identification number, along with material code number. For example, on the plug stem flats, the trim number and flow characteristic of the plug are identified.

Table 12: Oversize Actuator Weights (lbs / kg)

Original Size	Oversize	Add
25	50	30 / 14
50	100	90 / 41
100	200	125 / 57

Valtek Mark One

Standard Materials of Construction

Table 13: Packing

Configurations	Standard, Twin seal, Vacuum seal
Materials	Teflon V-ring, Teflon AFP*, AFP / Inconel wire, Glass-filled Teflon V-ring, Braided Teflon, Grafoil, other materials as required
Lubrication (optional)	Lubricator w/integral isolation valve Lubricator w/additional isolation valve

Table 14: Trim

Characteristics	Equal percentage, Linear, Quick opening
Materials	316 stainless steel Alloy 20 304 stainless steel Nickel 347 stainless steel Titanium 416 stainless steel Monel Hastelloy B 17-4 PH Hastelloy 440 C
Hard Facings Colmonoy	Materials: No.6 Stellite, No.5 Types: seat surface, full contour, full bore, lower stem guide area
Soft Seat	TFE Teflon, FEP Teflon, KEL-F, Polyurethane, PEEK
Pressure-balanced	Sizes: 2-inch and larger, Seal types: elastomer, metal

Table 15: Guides

Type	Double-top stem
Materials	Glass-filled Teflon, Grafoil, Stellite, bronze, other materials as required

Table 16: Gaskets

Types	Spiral wound: 304 or 316 stainless steel / non-asbestos filler, Teflon, Grafoil, Flat: Teflon, soft metal Metal O-ring: Inconel X750 / silver plated
-------	--

Table 17: Actuators

Types	Double acting cylinder with positive fail-safe spring action, Manual handwheel Electro-hydraulic Electro-mechanical
Sizes	Cylinder: 25, 50, 100 square inch (standard); 200, 300, 400, 500, 600 square inch (optional) Manual Handwheel: 9, 12, 18, 24-inch diameter
Auxiliary	Side-mounted: continuously connected Top-mounted: continuously connected, push-only, limit stops
Materials	Cylinder: anodized aluminum Piston: anodized aluminum Actuator stem: 416 stainless steel Yoke: ductile iron O-rings: Buna N
Action	Air-to-open, Air-to-close (field reversible)
Max. Working Pressure	150 psig / 10.3 Barg

Table 18: Positioner

Types	Pneumatic, Electro-pneumatic
Input Signals	Pneumatic: 3-15, 3-9, 9-15, 6-30 psig 0-1, 0-0.6, 0.6-1, 0.4-2.1 Barg and split ranges Electro-pneumatic: 4-20, 10-50 mA
Supply Pressure	40-150 psig / 2.8-10.3 Barg (no supply regulator required)
Standard Materials	Aluminum, stainless steel, Buna N, nickel-plated brass
Adjustments	Stroke range, zero, balance pressure
Action	Air-to-open, Air-to-close (field reversible)

*Asbestos Free Packing (AFP)

Valtek Mark One Dimensions



Table 19: Globe Body Dimensions – Class 150, 300, 600 (in. / mm)

Body Size (inches)	A								B		H				Clearance Above Actuator Required for Disassembly	
	ANSI / Globe*		ANSI / ISA**				Standard Bonnet				Extended Bonnet					
	Class 150, 300, 600		Class 150	Class 300	Class 600											
1/2 & 3/4	8.5	216	7.3	184	7.6	194	8.1†	206†	1.5	38	3.8	97	8.3	212	2.5	64
1	8.5	216	7.3	184	7.8	197	8.3	210	1.8	44	3.8	97	8.3	212	2.5	64
1 1/2	9.5	241	8.8	222	9.3	235	9.9	251	2.3	59	5.2	132	9.7	246	4.0	102
2	11.5	292	10.0	254	10.5	267	11.3	286	2.3	57	5.4	138	9.9	252	4.5	114
3	14.0	356	11.8	298	12.5	318	13.3	337	3.4	86	6.8	172	12.3	312	5.8	147
4	17.0	432	13.9	353	14.5	368	15.5	394	5.2	133	8.4	214	13.9	354	7.5	190
6			17.8	451					5.5	139	10.1	256	15.6	395	10.0	254
6					18.6	473	20.0	508	5.8	146	12.3	311	17.8	451	10.0	254
8			21.4	543					7.1	180	12.5	318	18.0	457	10.9	277
8					22.4	568	24.0	610	7.5	190	14.4	365	19.9	505	11.4	290
10			26.5	673					8.4	214	14.1	359	19.6	498	11.9	302
10					27.9	708	29.6	752	8.9	227	14.1	359	20.6	524	12.1	308
12			29.0	737					9.6	243	14.1	359	19.6	498	12.6	320
12					30.5	775	32.3	819			16.3	413	22.8	578	12.6	320

* Flowserve standard per ANSI / ISA S75.20, 1992

** Per ANSI / ISA S75.03, 1985

†For screwed end use 8.3 / 210

Table 20: Globe Body Dimensions – Class 900, 1500, 2500 (in. / mm)

Body Size (in.)	A				B				H				Clearance Required for Disassembly							
	Face-to-Face*				Class 1500		Class 2500		Standard Bonnet		Extended Bonnet									
	Class 900, 1500	Class 2500	Class 1500	Class 2500	Class 900, 1500	Class 2500	Class 900, 1500	Class 2500	Class 900, 1500	Class 2500	Class 900, 1500	Class 2500								
1	11.0	279	12.0 ²	305 ²	1.8	44	1.8	44	5.6	143	6.8	173	10.1	257	11.3	286	3.6	90	3.6	90
1 1/2	13.0	330	15.0 ¹	381 ¹	2.7	68	2.4	60	8.7	220	8.7	221	13.2	334	13.2	334	5.6	141	5.6	141
2	14.8	375	15.8	400	2.8	71	3.0	77	8.7	220	8.7	221	13.2	334	13.2	334	6.1	154	6.1	154
3	18.1	460	26.0 ¹	660 ¹	4.2	106	3.7	94	11.4	289	12.9	328	18.4	467	19.9	506	8.4	214	8.3	211
4	20.9	530	29.0 ¹	737 ¹	4.4	113	5.4	138	12.4	316	14.6	371	19.4	496	21.6	549	9.7	246	10.7	272
6	30.0 ²	762 ²	34.0 ¹	864 ¹	7.2	183	7.3	184	19.4	493	17.4	442	26.4	671	27.3	692	12.2	309	13.6	344
8	32.8	832	40.3	1022	9.4	240	10.3	262	18.6	473	24.3	616	24.2	613	31.3	794	16.7	424	17.8	451
10	39.0	991	50.0	1270	11.2	284	10.0	254	21.9	556	26.0	660	28.9	734	33.0	838	18.3	465	19.5	495
12	44.5	1130	56.0	1422	14.0	356	12.9	327	26.6	675	28.0	711	33.6	852	35.0	889	19.4	492	20.5	521
14	49.5	1257							24.8	629			31.8	806			20.5	521		

* ANSI / ISA S75.15, 1987; (1) Per ANSI / ISA S75.16, 1987; (2) Flowserve standard

Valtek Mark One Dimensions

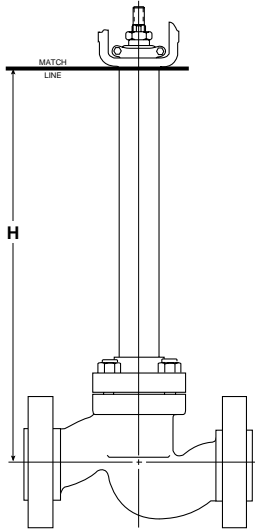
Table 21: Cold Box Extended Bonnet (in. / mm)

Body Size (inches)	Body Rating Class	H					
		Standard Cold Box Extension					
1/2 to 1	150 thru 600	15.0	381	24.0	610	27.0	686
1 1/2	150 thru 600	15.0	381	24.0	610	27.0	686
2	150 thru 600	15.3	387	24.3	616	27.3	692
3	150 thru 600	18.0	457	24.0	610	27.0	686
4	150 thru 600	18.0	457	24.0	610	27.0	686
6	150	18.0	457	24.0	610	27.0	686

Table 22 Angle Body (in. / mm)

Body Size (inches)	Body Rating Class	A	H				Clearance Required for Disassembly		
			Standard Bonnet		Extended Bonnet				
1/2 to 1	150 thru 600	4.3	108	3.1	78	7.6	192	2.5	64
1 1/2	150 thru 600	4.8	121	3.6	92	8.1	206	4.0	102
2	150 thru 600	5.8	146	3.9	100	8.4	214	4.5	114
3	150 thru 600	7.0	178	4.9	124	10.4	264	5.8	147
4	150 thru 600	8.8	222	6.2	156	11.7	295	7.5	190
	150	8.9	226	7.1	180	12.6	320	10.0	254
6	150	11.0	279	9.5	241	15.0	381	10.0	254
	300 thru 600	13.0	330	10.8	275	16.3	414	13.8	349
8	150	13.0	330	10.8	275	16.3	414	13.8	349
	300 thru 600	13.0	330	10.8	275	16.3	414	13.8	349

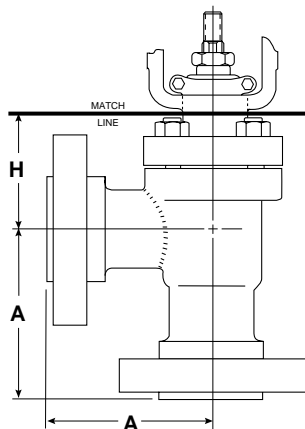

1/2 to 1	900, 1500	5.5	140	4.7	119	9.2	234	3.6	90
	2500	6.0	152	5.8	147	10.3	262	3.6	90
1 1/2	900, 1500	6.5	165	6.5	165	11.0	279	5.6	142
	2500	7.5	191	7.0	178	11.5	292	5.6	142
2	900, 1500	7.3	185	7.1	180	11.6	295	6.1	155
	2500	8.9	226	7.9	201	12.4	315	6.1	155
3	900, 1500	9.3	236	9.8	249	16.8	427	8.4	213
	2500	13.0	330	11.2	284	18.2	462	8.3	211
4	900, 1500	12.5	318	11.1	282	18.1	460	9.7	246
	2500	14.5	368	12.6	320	19.6	498	10.7	272
6	900, 1500	13.9	353	13.3	338	20.3	516	12.2	310
	2500	17.0	432	16.1	409	23.1	537	13.6	345
8	900, 1500	16.4	417	14.5	368	21.5	547	16.7	424
	2500	20.1	511	20.8	528	27.8	706	17.8	452
10	900, 1500	19.5	495	15.6	396	22.6	574	18.3	465
	2500	25.0	635	21.1	536	28.1	714	16.3	414

Valtek Mark One

Dimensions

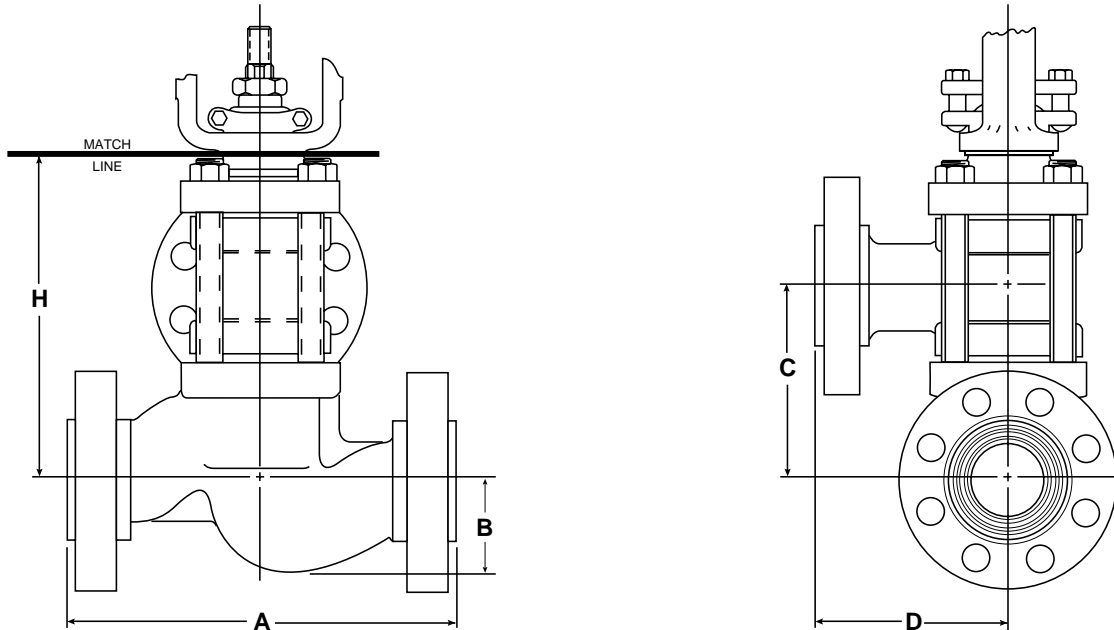
Table 23: Three-way Body (in. / mm)

Body Size (inches)	ANSI/ Globe Class 150,300,600		A						B		C		D		H				Clearance Required for Disassembly	
			ANSI/ISA												Std. Bonnet		Extd. Bonnet			
	Class 150		Class 300		Class 600															
1/2 & 3/4	8.5	216	7.3	184	7.6	194	8.1†	206†	1.5	38	3.4	87	4.3	108	6.7	170	11.2	284	3.4	86
1	8.5	216	7.3	184	7.8	197	8.3	210	1.8	44	3.4	87	4.3	108	6.7	170	11.2	284	3.4	86
1 1/2	9.5	241	8.8	222	9.3	235	9.9	251	2.3	59	5.4	137	4.8	121	9.1	230	13.4	341	5.0	127
2	11.5	292	10.0	254	10.5	267	11.3	286	2.3	59	5.6	143	5.8	146	9.3	236	13.7	347	5.5	140
3	14.0	356	11.8	298	12.5	318	13.3	337	3.4	86	7.6	194	7.0	178	13.0	329	18.5	470	7.1	181
4	17.0	432	13.9	353	14.5	368	15.5	394	5.2	133	9.9	251	8.5	216	16.7	423	22.1	562	9.4	240
6			17.8	451					5.5	139	14.0	356	8.9	226	21.6	548	26.6	675	11.6	294
6					18.6	473	20.0	508	5.8	146	16.0	406	10.0	254	25.8	654	31.3	794	11.6	294
8			21.4	543					7.0	179	15.0	381	10.7	272	23.9	608	29.4	748	12.2	310
8					22.4	568	24.0	610	7.5	191	18.3	464	12.0	305	30.2	767	35.7	907	12.2	310

* Per ANSI B16.10, 1986

** Per ANSI / ISA S75.03, 1985

†For screwed end use 8.3 / 210

Valtek Mark One



A four-inch Mark One with side-mounted handwheel operates in a boiler feedwater system at a pulp plant.



This two-inch Gaurdian II operates in a chemical plant.



This eight-inch, back-pressure control valve operates in a liquid hydrocarbon plant with a 580 psi / 40 Bar upstream pressure.

This cryogenic Mark One is used for aerospace testing as an LO₂ vent valve.



(Left) This series of valves is used to operate a PSA skid.

(Right) A liquid nitrogen loading facility in Australia uses two Mark Ones for its emergency fire water system.



Valtek Mark One

Flowserve Corporation has established industry leadership in the design and manufacture of its products. When properly selected, this Flowserve product is designed to perform its intended function safely during its useful life. However, the purchaser or user of Flowserve products should be aware that Flowserve products might be used in numerous applications under a wide variety of industrial service conditions. Although Flowserve can (and often does) provide general guidelines, it cannot provide specific data and warnings for all possible applications. The purchaser/user must therefore assume the ultimate responsibility for the proper sizing and selection, installation, operation and maintenance of Flowserve products. The purchaser/user should read and understand the Installation Operation Maintenance (IOM) instructions included with the product, and train its employees and contractors in the safe use of Flowserve products in connection with the specific application.

While the information and specifications presented in this literature are believed to be accurate, they are supplied for informative purposes only and should not be considered certified or as a guarantee of satisfactory results by reliance thereon. Nothing contained herein is to be construed as a warranty or guarantee, express or implied, regarding any matter with respect to this product. Because Flowserve is continually improving and upgrading its product design, the specifications, dimensions and information contained herein are subject to change without notice. Should any question arise concerning these provisions, the purchaser/user should contact Flowserve Corporation at any of its worldwide operations or offices.

All trademarks and tradenames shown in this literature are property of their respective owners.

For more information, contact:

For more information about Flowserve and its products, contact www.flowserve.com or call USA 972 443 6500

Manufacturing Facilities

1350 N. Mt. Springs Prkwy.
Springville, UT 84663
Phone 801 489 8611
Facsimile 801 489 3719

Manderscheidstr. 19
45141 Essen, Germany
Telephone (49) 2 01 89 19 5
Facsimile (49) 2 01 891 9600

Allée du Quartz 1
CH-2300 La Chaux-de-Fonds
Switzerland
Telephone (41) 32 925 9700
Facsimile (41) 32 926 5422

12, av. du Québec, B.P. 645
91965, Courtaboeuf Cedex, France
Telephone (33 1) 60 92 32 51
Facsimile (33 1) 60 92 32 99

Quick Response Centers

5114 Railroad Street
Deer Park, TX 77536 USA
Telephone 281 479 9500
Facsimile 281 479 8511

104 Chelsea Parkway
Boothwyn, PA 19061 USA
Telephone 610 497 8600
Facsimile 610 497 6680

1300 Parkway View Drive
Pittsburgh, PA 15205 USA
Telephone 412 787 8803
Facsimile 412 787 1944

