



1-LDC See-Thru Liquid Drainer

For Loads to 1,500 lb/hr (690 kg/hr)...Pressures to 150 psig (10 bar)

Now, you can literally see what you've been missing—the early warning signs of a drain trap or system problem. Since you'll know the operating condition of a drain trap, you won't waste time and money scheduling maintenance that isn't needed. In other words, you'll be able to react to a condition before it becomes a problem.

A free floating mechanism needs no electricity to operate, the 1-LDC discharges automatically only when liquid is present. That means no air loss as with timed devices that open even when liquid is not present. Moisture in a compressed air system causes problems. Getting the water out—automatically, reliably—builds greater efficiency into your system.

For a fully detailed certified drawing, refer to CD #1031.

List of Materials

Table LD-6.	
Name of Part	Material
Cap and Fitting	Reinforced Nylon*
Body	Polysulfone
O-Rings (Cap, Body and Fitting)	Nitrile Elastomer Compound
Float, Lever and Screws	Stainless Steel
Valve & Seat	Stainless Steel
Retainer Ring	Zinc-Plated Steel

*UV sensitive

Maximum Operation Pressures and Capacities

Table LD-7.		1.0				0.95			
Orifice Size	Maximum Operating Pressure		Capacity		Maximum Operating Pressure		Capacity		
	psi	bar	lb/hr	kg/hr	psi	bar	lb/hr	kg/hr	
1/8	121	8.3	1,500	690	109	7.6	1,400	640	
#38	150	10.0	1,100	510	150	10.0	1,100	490	

Capacities given are continuous discharge capacities in lb/hr or kg/hr of liquid at pressure differential indicated.

Physical Data

Table LD-8.		
Inlet Connections	in	mm
		1/2, 3/4
Outlet Connection	1/2	15
Alternate Inlet or Vent Connection	1/2, 3/4	15, 20
"A"	3-1/2	89
"B"	6-7/8	175
"C"	6-3/32	155
Weight lbs (kg)	1 (0.45)	
Maximum Allowable Pressure (Vessel Design)	150 psig @ 150°F (10 bar @ 65°C)	
Maximum Operating Pressure psig (bar)	150 (10)	

How to Order

Body Inlet ①	Cap Inlet ②	Cap Outlet ③
3/4"	1/2"	1/2"
1/2" or 3/4"	1/2" or 3/4"	1/2"

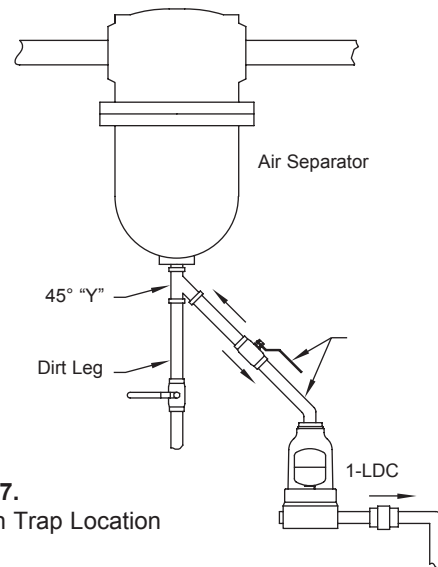
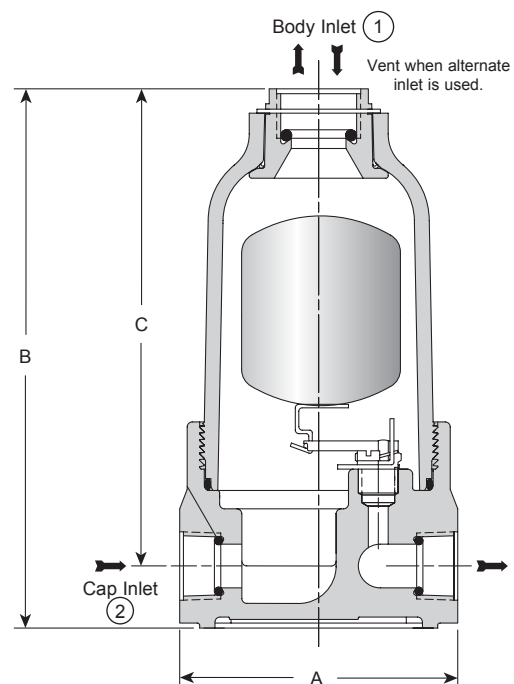

Figure LD-27. Typical Drain Trap Location

Drain traps dispose of water that collects in many places in a compressed air system. Each drain trap arrangement must be considered individually.

Figure LD-28.



*last updated 11/15



Free Floating Lever Drain Traps

For Loads to 50,000 lb/hr (22,679 kg/hr)...Pressures to 1,000 psig (69 bar)

Table LD-14. Maximum Operating Pressures for Handling Different Specific Gravity Liquids With Orifices Available in Guided Free Floating Lever Drain Traps. (See pages LD-29 and LD-30.)

Model No.	Sp. Grav Orifice	1.00		.95		.90		.85		.80		.75		.70		.65		.60		.55		.50			
		Maximum Operating Pressure psig (bar)																							
		in	psig	bar	psig	bar	psig	bar	psig	bar	psig	bar	psig	bar	psig	bar	psig	bar	psig	bar	psig	bar	psig	bar	
1-LD	1/8	121	8.3	109	7.6	98	6.8	87	6.0	75	5.2	64	4.4	52	3.6	41	2.8	29	2.0	18	1.2	6	0.4		
	7/64	143	9.9	130	9.0	116	8.0	103	7.1	89	6.1	75	5.2	62	4.3	48	3.3	35	2.4	21	1.4	7	0.5		
	#38	182	12.5	164	11	147	10.2	130	9.0	113	7.8	95	6.6	78	5.4	61	4.2	44	3.0	26	1.8	9	0.6		
	5/64	300	20.7	289	19.9	259	17.8	228	15.7	198	13.7	168	11.6	137	9.5	107	7.4	77	5.3	47	3.2	16	1.1		
11-LD	1/8	176	12.1	161	11.1	146	10.1	130	9.0	115	7.9	100	6.9	85	5.8	69	4.8	54	3.7	39	2.7	24	1.6		
	7/64	209	14	191	13	173	12	155	10.7	137	9.4	119	8.2	100	6.9	82	5.7	64	4.4	46	3.2	28	1.9		
	#38	264	18	242	17	219	15	196	14	173	12	150	10.4	127	8.8	104	7.2	81	5.6	59	4.0	36	2.5		
	5/64	400	28	400	28	384	27	344	24	304	21	264	18	224	15	183	13	143	9.9	103	7.1	63	4.3		
2-LD to 250 psi (17 bar)	5/16	22	1.5	20	1.4	18	1.3	17	1.1	15	1.0	13	0.9	11	0.8	10	0.7	8	0.5	6	0.4	4	0.3		
	1/4	36	2.5	33	2.3	30	2.1	27	1.9	24	1.7	22	1.5	19	1.3	16	1.1	13	0.9	10	0.7	7	0.5		
	3/16	79	5.5	73	5.0	67	4.6	60	4.2	54	3.7	47	3.3	41	2.8	35	2.4	28	2.0	22	1.5	16	1.1		
	5/32	137	9.4	126	8.7	115	7.9	104	7.2	93	6.4	82	5.6	71	4.9	60	4.1	49	3.4	38	2.6	27	1.8		
22-LD to 533 psi (37 bar)	1/8	234	16.1	215	14.8	196	13.5	178	12.2	159	10.9	140	9.6	121	8.4	102	7.1	83	5.8	65	4.5	46	3.2		
	7/64	299	20.6	275	19	251	17.3	227	15.7	203	14	179	12	155	10.7	131	9.0	107	7.4	83	5.7	59	4.0		
	#38	372	25.7	342	23.6	313	21.6	283	19.5	253	17.4	223	15	193	13	163	11.2	133	9.2	103	7.1	73	5.0		
	5/64	533	37	475	33	461	32	417	29	372	26	328	23	284	20	240	17	196	14	152	10.5	108	7.4		
32-LD	5/16	29	2.0	26	1.8	23	1.6	21	1.4	18	1.2	15	1.0	12	0.9	10	0.7	7	0.5	4	0.3	2	0.1		
	1/4	47	3.3	43	3.0	38	2.6	34	2.3	29	2.0	25	1.7	20	1.4	16	1.1	12	0.8	7	0.5	3	0.2		
	3/16	104	7.2	94	6.5	85	5.8	75	5.2	65	4.5	55	3.8	45	3.1	35	2.4	25	1.8	16	1.1	6	0.4		
	5/32	180	12	163	11	146	10	129	8.9	112	7.7	95	6.5	78	5.4	61	4.2	44	3.0	27	1.9	10	0.7		
	1/8	307	21	278	19	249	17	220	15	191	13	162	11	133	9	104	7.2	75	5.2	46	3.2	17	1.2		
	7/64	393	27	356	25	319	22	282	19	245	17	207	14	170	12	133	9	96	6.6	59	4.1	22	1.5		
3-LD to 250 psi (17 bar) (Cast Iron)	1/2	16	1.1	14	1.0	13	0.9	12	0.8	10	0.7	9	0.6	7	0.5	6	0.4	5	0.3	3	0.2	2	0.1		
	3/8	33	2.3	31	2.1	28	1.9	25	1.7	22	1.5	19	1.3	16	1.1	13	0.9	10	0.7	7	0.5	4	0.3		
	5/16	54	3.7	49	3.4	44	3.0	39	2.7	35	2.4	30	2.1	25	1.7	20	1.4	16	1.1	11	0.8	6	0.4		
	9/32	71	4.9	65	4.5	59	4.0	52	3.6	46	3.2	40	2.7	34	2.3	27	1.9	21	1.4	15	1.0	8	0.6		
13-LD to 570 psi (39 bar) (Stainless)	1/4	107	7.4	97	6.7	88	6.1	79	5.4	69	4.8	60	4.1	50	3.5	41	2.8	32	2.2	22	1.5	13	0.9		
	7/32	153	10.5	139	9.6	126	8.7	112	7.7	99	6.8	85	5.9	72	5.0	59	4.0	45	3.1	32	2.2	18	1.2		
	3/16	230	16	209	14	189	13	169	12	149	10.3	129	8.9	108	7.5	88	6.1	68	4.7	48	3.3	27	1.9		
33-LD to 900 psi (62 bar) (Steel)	5/32	359	25	327	23	296	20	264	18	233	16	201	14	169	12	138	9.5	106	7.3	74	5.1	43	2.9		
	1/8	726	50	662	46	598	41	534	37	470	32	406	28	342	24	278	19	214	15	150	10.3	86	5.9		
	7/64	900	62	847	58	765	53	683	47	601	41	519	36	437	30	356	25	274	19	192	13	110	7.6		
6-LD Cast Iron	1-1/16	21	1.4	19	1.3	18	1.2	16	1.1	15	1.0	13	0.9	12	0.8	10	0.7	9	0.6	7	0.5	6	0.4		
	7/8	32	2.2	30	2.1	28	1.9	26	1.8	23	1.6	21	1.4	19	1.3	16	1.1	14	1.0	12	0.8	9	0.6		
	3/4	47	3.2	44	3.0	40	2.8	37	2.5	34	2.3	30	2.1	27	1.9	24	1.6	20	1.4	17	1.2	14	0.9		
	5/8	72	4.9	67	4.6	61	4.2	56	3.9	51	3.5	46	3.2	41	2.8	36	2.5	31	2.1	26	1.8	21	1.4		
	9/16	95	6.5	88	6.1	81	5.6	75	5.2	68	4.7	61	4.2	55	3.8	48	3.3	41	2.8	34	2.4	28	1.9		
	1/2	138	9.5	128	8.8	118	8.1	108	7.5	99	6.8	89	6.1	79	5.4	69	4.8	59	4.1	50	3.4	40	2.8		
	7/16	196	13	182	13	168	12	154	11	140	10	126	8.7	112	7.7	98	6.8	85	5.8	71	4.9	57	3.9		
	3/8	250	17	250	17	250	17	243	17	221	15	199	14	177	12	155	11	133	9.0	111	7.7	90	6.2		
	11/32	250	17	250	17	250	17	250	17	250	17	250	17	250	17	236	16	207	14	178	12	148	10	119	8.2
	5/16	250	17	250	17	250	17	250	17	250	17	250	17	250	17	250	17	250	17	228	16	191	13	153	11
	9/32	250	17	250	17	250	17	250	17	250	17	250	17	250	17	250	17	250	17	250	17	250	17	201	14
	1/4	250	17	250	17	250	17	250	17	250	17	250	17	250	17	250	17	250	17	250	17	250	17	250	17
7/32	250	17	250	17	250	17	250	17	250	17	250	17	250	17	250	17	250	17	250	17	250	17	250	17	
3/16	250	17	250	17	250	17	250	17	250	17	250	17	250	17	250	17	250	17	250	17	250	17	250	17	
36-LD Forged Steel	1-1/16	16	1.1	15	1.01	13	0.91	12	0.81	10	0.71	9	0.6	7	0.5	6	0.4	4	0.3	3	0.2	1	0.1		
	7/8	25	1.7	23	1.6	21	1.4	18	1.3	16	1.1	14	0.95	11	0.79	9	0.63	7	0.47	5	0.31	2	0.16		
	3/4	36	2.5	33	2.3	30	2.1	27	1.8	23	1.6	20	1.4	17	1.1	13	0.91	10	0.68	7	0.45	3	0.22		
	5/8	56	3.9	51	3.5	46	3.1	41	2.8	35	2.4	30	2.1	25	1.7	20	1.4	15	1.05	10	0.69	5	0.34		
	9/16	74	5.1	67	4.6	60	4.2	54	3.7	47	3.2	40	2.8	34	2.3	27	1.8	20	1.4	13	0.92	7	0.46		
	1/2	107	7.4	97	6.7	88	6.0	78	5.4	68	4.7	58	4.0	49	3.4	39	2.7	29	2.0	19	1.3	10	0.66		
	7/16	152	10.5	138	9.6	125	8.6	111	7.6	97	6.7	83	5.7	69	4.8	55	3.8	41	2.9	27	1.9	14	0.94		
	3/8	240	17	218	15	197	14	175	12	153	10.5	131	9.0	109	7.5	87	6.0	65	4.5	43	3.0	21	1.5		
	11/32	320	22	291	20	262	18	233	16	203	14	174	12	145	10	116	8.0	87	6.0	58	4.0	29	2.0		
	5/16	411	28	374	26	336	23	299	21	262	18	224	15	187	13	149	10.3	112	7.7	74	5.1	37	2.5		
	9/32	539	37	490	34	441	30	392	27	343	24	293	20	244	17	195	13	146	10.1	97	6.7	48	3.3		
	1/4	788	54	716	49	644	44	573	39	501	35	429	30	357	25	286	20	214	15	142	9.8	70	4.9		
7/32	1,000	69	1,000	69	910	63	808	56	707	49	606	42	505	35	403	28	302	21	201	14	99	6.9			
3/16	1,000	69	1,000	69	1,000	69	1,000	69	1,000	69	992	68	826	57	660	46	494	34	328	23	163	11.2			
Specific Gravity		1.00		.95		.90		.85		.80		.75		.70		.65		.60		.55		.50			

NOTE: If specific gravity falls between those shown in the chart, use the next lower gravity. For example, if specific gravity is 0.73, use 0.70 gravity data.

High Temperature Service

Maximum allowable working pressures of floats decrease at temperatures above 100°F (37.8°C). Allow for approximately:

- 10% decrease at 200°F (93.3°C)
- 15% decrease at 300°F (148.9°C)
- 2