



PYTHON® 1500 SERIES CONTROL VALVES

Pneumatic and Electric Actuated





Armstrong® Python® - 1500 Series Control Valves

Table of Contents

Features and Benefits.....	3
Specifications, Weights, and Dimensions.....	4-5
Trim Options and CV Values.....	6
Pneumatic Actuators.....	7
Pneumatic Actuated Shut Off Charts	8 - 11
Pneumatic Actuated Model Identification.....	12
CV1500BEL - Belimo Electric Actuator	13
CV1500AEL - AEL Electric Actuator	14 - 16
Electric Actuated Model Identification.....	17
Sizing Example.....	18

Python® - 1500 Series Control Valves

Control valves are a key component in any pressure or temperature control application. With the increasing cost of fuel, delivering media in the most efficient way increases productivity by delivering the required pressure or temperature while avoiding excessive consumption. Precision control also provides repeatability and safety for any process.

Features

- Series 1500 valves are globe two-way single seated design valves, which deliver accurate and efficient control for most steam and liquid applications
- Body with top entry trim and bolted bonnet facilitates easy access to all internal parts for in-line inspection, maintenance, and trim replacement
- Carbon steel and stainless steel materials
- 2 Packings: Carbon filled PTFE chevron seals and grafoil
- Electric actuators for on/off and modulating characteristics
- Equal percentage and Linear characteristic trims for accurate control
- Pressure balanced configuration for improved shut off and high pressure applications
- Metal to metal seats rated for Class IV shut off
- Optional PTFE soft seat for Class VI shut off
- 17-4 PH h900 and Stellite plugs and seat for long service and better resistance
- 50:1 Rangeability
- Two pneumatic actuators per valve size
- 6-spring actuator design allows lower hysteresis and higher performance
- Pneumatic actuators tested to over 4 million cycles
- Live spring loaded teflon packing for long service and less maintenance

Accessories

Positioners

- Pneumatic
- Electro-Pneumatic
- Digital

Controllers

- Pneumatic
- Electric

Transmitters

Temperature sensors

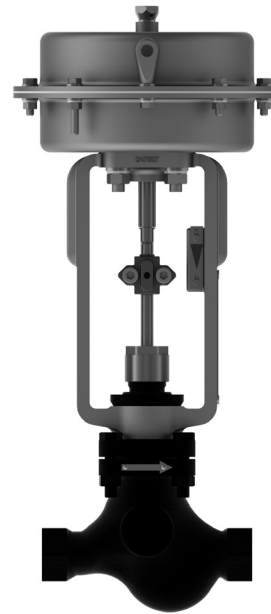

Python® Series
1500 Control Valve -
Threaded Connection

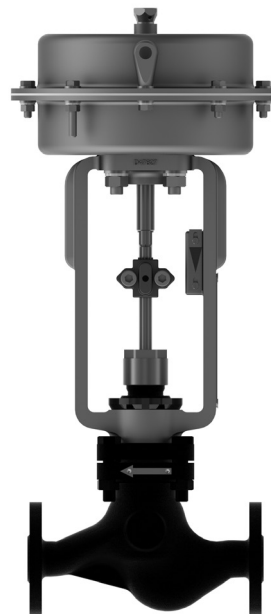

Python® Series
1500 Control Valve -
Flanged Connection



Armstrong® Python® - 1500 Series Control Valves

List of Materials

Valve Body	Carbon Steel A216 Gr. WCB
Bonnet	Stainless Steel CF8M
Valve/Valve Seat	17-4 PH h900 / Standard Stellite / Option PTFE Soft Seat / Option - 388F (198C) Max.
Valve Spindle	ANSI SS 431
Gland Packing	Carbon Filled V-Teflon - option 1 (450°F (232°C) Max.) Grafoil - option 2 (800°F (427°C) Max.)
Yoke	Ductile Iron
Actuator Spring	SiCr Spring Steel
Actuator Diaphragm	Nitrile Reinforced with Nylon Fiber
Cage Material	ASTM A743 Gr CB30
Sealing Ring Material	Carbon Filled V-Teflon

Technical Data

Flow Characteristic	Equal Percentage and Linear	
Leakage	ANSI Class IV (Metal to Metal) ANSI Class VI (PTFE Soft Seat)	
Rangeability	50:1	
Travel	1/2" to 1-1/2"	13/16" (20 mm)
	2"	1-3/16" (30 mm)
	2-1/2" to 4"	1-9/16" (40 mm)

Dimensions and Weights - 174 cm² Actuator and Valve

Size		Face-to-Face "L"						"C"		"D"		"H"		Weight					
in	mm	NPT		150#		300#								NPT		150#		300#	
		in	mm	in	mm	in	mm	in	mm	in	mm	in	mm	lb	kg	lb	kg	lb	kg
1/2	15	6-1/2	165	7-1/4	184	7-1/2	190	5-7/8	150	8-1/4	210	16-3/4	426	29	13	29	13	29	13
3/4	20	6-1/2	165	7-1/4	184	7-5/8	194	5-7/8	150	8-1/4	210	16-3/4	426	29	13	29	13	31	14
1	25	7-3/4	197	7-1/4	184	7-3/4	197	5-7/8	150	8-1/4	210	16-3/4	426	33	15	35	16	37	17
1-1/4	32	9-1/4	235	8	203	8-1/2	216	5-7/8	150	8-1/4	210	17-3/4	451	35	16	37	17	42	19
1-1/2	40	9-1/4	235	8-3/4	222	9-1/4	235	5-7/8	150	8-1/4	210	17-3/4	451	37	17	40	18	46	21

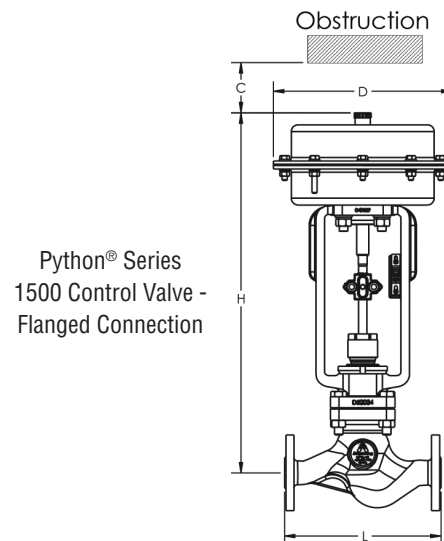
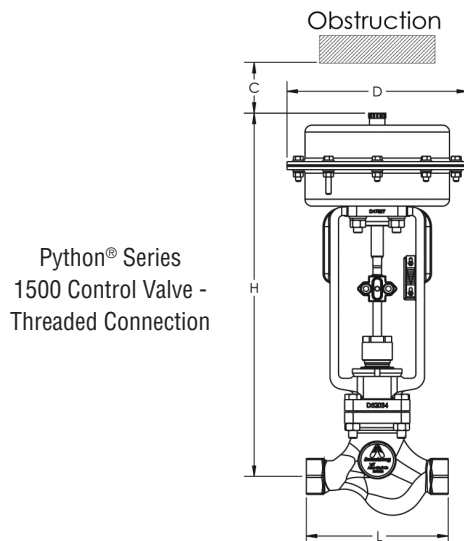

Designs, materials, weights and performance ratings are approximate and subject to change without notice. Visit armstronginternational.com for up-to-date information.

Python® - 1500 Series Control Valves



Dimensions & Weight -348 cm² Actuator and Valve

Size		Face-to-Face "L"						"C"		"D"		"H"		Weight					
in	mm	NPT		150#		300#		in	mm	in	mm	in	mm	NPT		150#		300#	
		in	mm	in	mm	in	mm							lb	kg	lb	kg	lb	kg
1/2	15	6-1/2	165	7-1/4	184	7-1/2	190	5-7/8	150	11	280	18-3/4	477	46	21	46	21	46	21
3/4	20	6-1/2	165	7-1/4	184	7-5/8	194	5-7/8	150	11	280	18-3/4	477	46	21	46	21	49	22
1	25	7-3/4	197	7-1/4	184	7-3/4	197	5-7/8	150	11	280	18-3/4	477	51	23	53	24	55	25
1-1/4	32	9-1/4	235	8	203	8-1/2	216	5-7/8	150	11	280	19-3/4	502	53	24	55	25	60	27
1-1/2	40	9-1/4	235	8-3/4	222	9-1/4	235	5-7/8	150	11	280	19-3/4	502	55	25	53	26	64	29
2	50	10-1/2	267	10	254	10-1/2	267	5-7/8	150	11	280	19-7/8	504	71	32	77	35	82	37
2-1/2	65	-	-	10-13/16	276	11-1/2	292	5-7/8	150	11	280	23-7/16	595	-	-	129	59	132	60
3	80	-	-	11-3/4	298	12-1/2	322	5-7/8	150	11	280	23-13/16	605	-	-	150	68	158	72
4	100	-	-	13-13/16	352	14-1/2	374	5-7/8	150	11	280	25	635	-	-	204	93	222	101

Dimensions & Weight -700 cm² Actuator and Valve

Size		Face-to-Face "L"				"C"		"D"		"H"		Weight			
in	mm	150#		300#		in	mm	in	mm	in	mm	150#		300#	
		in	mm	in	mm							lb	kg	lb	kg
2	50	10	254	10-1/2	267	5-7/8	150	16	400	24-1/8	613	141	64	147	67
2-1/2	65	10-13/16	276	11-1/2	292	5-7/8	150	16	400	26-7/16	671	189	86	192	87
3	80	11-3/4	298	12-1/2	322	5-7/8	150	16	400	26-13/16	681	210	95	218	99
4	100	13-13/16	352	14-1/2	374	5-7/8	150	16	400	27-15/16	708	264	120	282	128

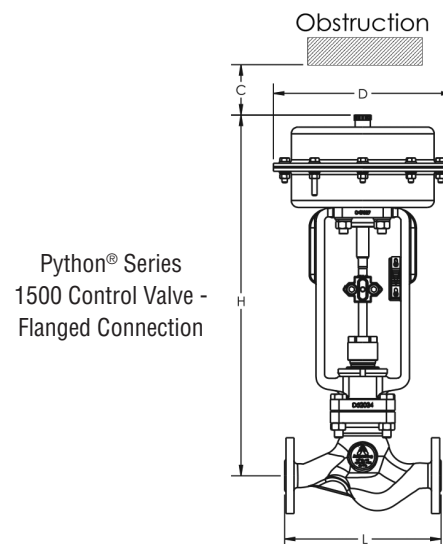
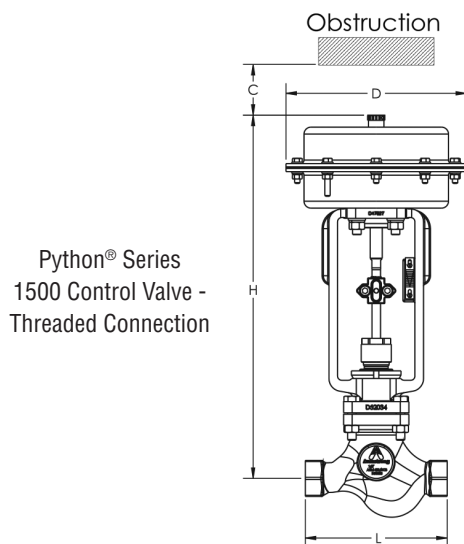

Designs, materials, weights and performance ratings are approximate and subject to change without notice. Visit armstronginternational.com for up-to-date information.



Armstrong® Python® - 1500 Series Control Valves

Trim Type

Contour Top Guided Parabolic Unbalanced

Equal percentage characteristic is ideal for temperature and flow control applications, or valves in parallel. This trim style is the most widely used for accurate control and precise repeatability.

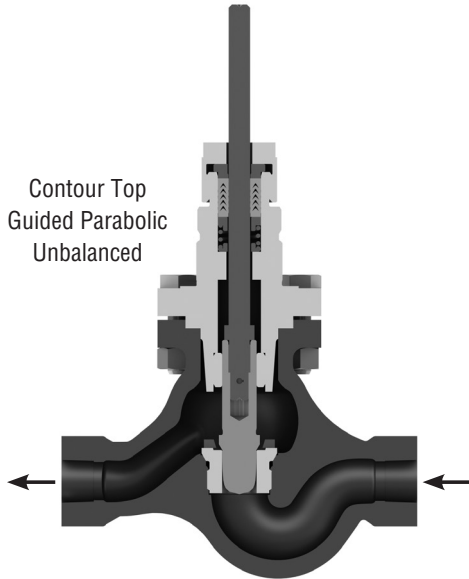

Contour Top Guided Parabolic Unbalanced

Cage Guided Parabolic Pressure Balanced

Cage Guided Pressure Balanced is ideal for high pressure applications where the top guided trim may not have adequate shut off capabilities. A balanced trim equalizes the pressure acting above and below the plug, reducing required actuator thrust. This results in a higher shut off capability and a smaller foot print while providing precise control of the application.

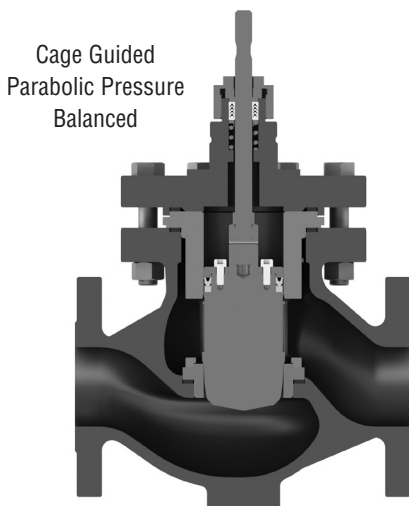

Cage Guided Parabolic Pressure Balanced

Table 4-1. CV1500 CV Values

Valve Size		Trim Size		CV
in	mm	in	mm	
1/2 3/4 1	15 20 25	1/8	3	0.12
		5/32	4	0.3
		3/16	5	0.5
		1/4	6	0.7
		9/32	7	1.2
		7/16	11	3
		1/2	16	5
		3/4	18	9
1-1/4	32	1	24	13
		3/4	18	9
		1-1/4	32	21
1-1/2	40	1	24	13
		1-1/4	32	21
		1-1/2	38	30
2	50	1-1/4	32	21
		1-1/2	38	30
		2	50	50
2-1/2	65	1-1/2	38	30
		2	50	50
		2-1/2	65	80
3	80	2	50	50
		2-1/2	65	80
		3	80	110
4	100	2-1/2	65	80
		3	80	110
		4	100	185



Python® - 1500 Series Control Valves

Multi-Spring Actuators

Multi-Spring Actuators are diaphragm actuators with pre-compressed, multi-spring construction. They are compact, easy to maintain, and are suitable for both modulating and on/off applications. Models are available covering small to large thrust requirements.

Specifications

- Maximum Diaphragm Pressure:
60 psig (4 barg) for model 174, 348 and 700
- Actuator travel:
174: 20mm
348: 20mm/30mm/40mm
700: 30mm/40mm
- Diaphragm:
Nitrile reinforced with Nylon fiber
- Operating Temperature Range:
-40° to 176°F (-40° to 80°C)
- Connections:
1/4" NPT (F) for Models 174, 348 and 700
- Permissible Linearity and Hysteresis:
±5% of Signal Pressure Range

Features:

- Construction – Due to multi-spring arrangement, the actuators are lightweight and compact.
- Long service life – Rigid, rolling diaphragm construction and durable components provide a long lasting service life.
- Minimum maintenance – The actuators are virtually maintenance free.
- Accuracy – Rolling diaphragm construction provides a constant effective area throughout the stroke.
- Tested to over 4 million full stroke cycles.

Direct Acting Actuators (Fail Open)

The actuator stem moves downward with increasing diaphragm pressure. When this pressure is reduced, the opposing spring force moves the actuator stem upward. On air failure, the actuator stem is pulled to the extreme upward position by spring force.

Reverse Acting Actuators (Fail Close)

The actuator stem moves upward with increasing diaphragm pressure. When this pressure is reduced the opposing spring force moves the actuator stem downward. On air failure, the actuator stem is pushed to extreme downward position by spring force.

Table 5-1. Air Volume Required Per Stroke

Model Number	Cubic Feet/Stroke
174cm ² 20mm	0.014 ft ³ (0.0004 m ³)
348cm ² 20mm	0.027 ft ³ (0.0008 m ³)
348cm ² 30mm	0.041 ft ³ (0.0012 m ³)
348cm ² 40mm	0.053 cu.ft/stroke (0.0015 m ³)
700cm ² 30mm	0.085 cu.ft/stroke (0.0024 m ³)
700cm ² 40mm	0.113 cu.ft/stroke (0.0032 m ³)

Pressure Temperature Rating for Carbon Steel Valves

Temp °F (°C)	Class 150 psig (barg)	Class 300 psig (barg)
100 (38)	285 (20)	740 (51)
200 (93)	260 (18)	675 (47)
300 (149)	230 (16)	655 (45)
400 (204)	200 (14)	635 (44)
500 (260)	170 (12)	600 (41)
600 (316)	140 (10)	550 (38)
650 (343)	125 (9)	535 (37)
700 (371)	110 (8)	535 (37)
750 (399)	95 (7)	505 (35)
800 (427)	80 (6)	410 (28)

Pressure Temperature Rating for CF8M Valves

Temp °F (°C)	Class 150 psig (barg)	Class 300 psig (barg)
up to 100 (38)	275 (19)	720 (50)
200 (93)	235 (16)	620 (42)
300 (149)	215 (15)	560 (39)
400 (204)	195 (14)	515 (36)
500 (260)	170 (12)	480 (33)
600 (316)	140 (10)	450 (32)
650 (343)	125 (9)	445 (31)
700 (371)	110 (8)	430 (30)



Armstrong® Python® - 1500 Series Control Valves

Table 8 - 1. Contoured Top Guided (Parabolic Unbalanced) for Reverse Acting Actuator

Actuator Model No.	Min. Air Supply to Actuator W/ Positioner	Spring Range	Diap. Area	Maximum Differential Pressure psig (barg) / Δ P / Shut Off Pressure															
				Trim Size															
				CV	0.12	0.3	0.5	0.7	1.2	3	5	9	13	21	30	50	85	110	185
psig (barg)	psig (barg)	Inch ²	1/8"	5/32"	3/16"	1/4"	9/32"	7/16"	1/2"	3/4"	1"	1 - 1/4"	1 - 1/2"	2"	2 - 1/2"	3"	4"		
174 20mm	20 (1.3)	3-15 (0.2 - 1)	27in ²	725 (50)	725 (50)	725 (50)	725 (50)	725 (50)	478 (33)	214 (15)	156 (11)	87 (6)	44 (3)	29 (2)	-	-	-	-	
	23 (1.5)	6-18 (0.4 - 1.2)		725 (50)	725 (50)	725 (50)	725 (50)	725 (50)	725 (50)	465 (32)	344 (24)	198 (14)	107 (7)	73 (5)	-	-	-	-	
	37 (2.5)	9-32 (0.6 - 2.2)		725 (50)	725 (50)	725 (50)	725 (50)	725 (50)	725 (50)	716 (49)	530 (37)	310 (21)	170 (12)	118 (8)	-	-	-	-	
	43 (2.9)	16-38 (1.1 - 2.6)		725 (50)	725 (50)	725 (50)	725 (50)	725 (50)	725 (50)	725 (50)	725 (50)	590 (41)	326 (23)	229 (16)	-	-	-	-	
348 20mm	20 (1.3)	3-15 (0.2 - 1)	54in ²	725 (50)	725 (50)	725 (50)	725 (50)	725 (50)	725 (50)	725 (50)	344 (24)	198 (14)	107 (7)	73 (5)	-	-	-	-	
	23 (1.5)	6-18 (0.4 - 1.2)		725 (50)	725 (50)	725 (50)	725 (50)	725 (50)	725 (50)	725 (50)	725 (50)	421 (29)	232 (16)	162 (11)	-	-	-	-	
348 30mm	20 (1.3)	3-15 (0.2 - 1)	54in ²	-	-	-	-	-	-	-	-	-	107 (7) *	73 (5) *	39 (3)	-	-	-	
	23 (1.5)	6-18 (0.4 - 1.2)		-	-	-	-	-	-	-	-	-	-	232 (16) *	162 (11) *	91 (6)	-	-	-
	37 (2.5)	9-32 (0.6 - 2.2)		-	-	-	-	-	-	-	-	-	-	358 (25) *	251 (17) *	142 (10)	-	-	-
	43 (2.9)	16-38 (1.1 - 2.6)		-	-	-	-	-	-	-	-	-	-	671 (46) *	474 (33) *	271 (19)	-	-	-
348 40mm	20 (1.3)	3-15 (0.2 - 1)	54in ²	-	-	-	-	-	-	-	-	-	-	-	-	21 (2)	13 (.9)	7 (.5)	
	23 (1.5)	6-18 (0.4 - 1.2)		-	-	-	-	-	-	-	-	-	-	-	-	52 (4)	33 (2)	20 (1.4)	
	43 (2.9)	16-38 (1.1 - 2.6)		-	-	-	-	-	-	-	-	-	-	-	-	158 (11)	103 (7)	65 (5)	
700 30mm	20 (1.3)	3-15 (0.2 - 1)	108in ²	-	-	-	-	-	-	-	-	-	234 (16) *	164 (11) *	92 (6)	-	-	-	
	23 (1.5)	6-18 (0.4 - 1.2)		-	-	-	-	-	-	-	-	-	-	487 (33) *	343 (24) *	195 (14)	-	-	-
	43 (2.9)	16-38 (1.1 - 2.6)		-	-	-	-	-	-	-	-	-	-	725 (50) *	725 (50) *	557 (38)	-	-	-
700 40mm	20 (1.3)	3-15 (0.2 - 1)	108in ²	-	-	-	-	-	-	-	-	-	-	-	-	52 (4)	33 (2)	20 (1)	
	23 (1.5)	6-18 (0.4 - 1.2)		-	-	-	-	-	-	-	-	-	-	-	-	113 (8)	74 (5)	46 (3)	
	43 (2.9)	16-38 (1.1 - 2.6)		-	-	-	-	-	-	-	-	-	-	-	-	328 (23)	215 (15)	136 (9)	

* Indicates 2" valve with reduced port trim

Do not exceed 60 psigg (4 barg) air pressure to the actuator.

The data above includes both equal percentage and linear shut off pressure.

Python® - 1500 Series Control Valves



Table 9 - 2. Contoured Top Guided (Parabolic Unbalanced) for Direct Acting Actuator

Actuator Model No.	Min. Air Supply to Actuator W/ Positioner	Spring Range	Diap. Area	Maximun Differential Pressure psig (barg) Δ P / Shut Off Pressure															
				Trim Size															
				CV	0.12	0.3	0.5	0.7	1.2	3	5	9	13	21	30	50	85	110	185
psig (barg)	psig (barg)	Inch ²	1/8"	5/32"	3/16"	1/4"	9/32"	7/16"	1/2"	3/4"	1"	1-1/4"	1-1/2"	2"	2-1/2"	3"	4"		
174 20mm	18 (1.2)	3-15 (0.2 - 1)	27in ²	-	-	-	-	-	-	-	-	-	-	-	-	-	-	-	
	22 (1.5)			725 (50)	725 (50)	725 (50)	725 (50)	725 (50)	664 (46)	303 (21)	222 (15)	126 (9)	67 (5)	45 (3)	-	-	-	-	
	29 (2)			-	-	-	-	-	725 (50)	725 (50)	691 (48)	405 (28)	223 (15)	156 (11)	-	-	-	-	
	36 (2.5)			-	-	-	-	-	-	-	725 (50)	684 (47)	380 (26)	267 (18)	-	-	-	-	
	44 (3)			-	-	-	-	-	-	-	-	725 (50)	537 (37)	378 (26)	-	-	-	-	
	51 (3.5)			-	-	-	-	-	-	-	-	725 (50)	694 (48)	490 (34)	-	-	-	-	
	58 (4)			-	-	-	-	-	-	-	-	-	725 (50)	601 (41)	-	-	-	-	
348 20mm	18 (1.2)	3-15 (0.2 - 1)	54in ²	725 (50)	725 (50)	725 (50)	725 (50)	725 (50)	399 (28)	177 (12)	128 (9)	71 (5)	35 (2.5)	23 (1.6)	-	-	-	-	
	22 (1.5)			-	-	-	-	-	725 (50)	725 (50)	691 (48)	405 (28)	223 (15)	156 (11)	-	-	-	-	
	29 (2)			-	-	-	-	-	-	-	725 (50)	725 (50)	537 (37)	378 (26)	-	-	-	-	
	36 (2.5)			-	-	-	-	-	-	-	-	725 (50)	601 (41)	-	-	-	-	-	
	44 (3)			-	-	-	-	-	-	-	-	-	725 (50)	-	-	-	-	-	
348 30mm & 40mm	18 (1.2)	3-15 (0.2 - 1)	54in ²	-	-	-	-	-	-	-	-	-	10 (.7)	10 (.7)	-	-	-	-	
	22 (1.5)			-	-	-	-	-	-	-	-	-	205 (14)	143 (10)	80 (6)	45 (3)	29 (2)	-	
	29 (2)			-	-	-	-	-	-	-	-	-	519 (36)	366 (25)	208 (14)	121 (8)	79 (5)	-	
	36 (2.5)			-	-	-	-	-	-	-	-	-	725 (50)	588 (41)	337 (23)	197 (14)	129 (9)	-	
	44 (3)			-	-	-	-	-	-	-	-	-	-	725 (50)	465 (32)	273 (19)	179 (12)	-	
	51 (3.5)			-	-	-	-	-	-	-	-	-	-	-	-	594 (41)	349 (24)	229 (16)	-
	58 (4)			-	-	-	-	-	-	-	-	-	-	-	-	722 (50)	425 (29)	279 (19)	-
700 30mm & 40mm	18 (1.2)	3-15 (0.2 - 1)	108in ²	-	-	-	-	-	-	-	-	-	144 (10)	100 (7)	55 (4)	30 (2)	19 (1)	11 (1)	
	22 (1.5)			-	-	-	-	-	-	-	-	-	523 (36)	368 (25)	210 (14)	122 (8)	79 (5)	50 (3)	
	29 (2)			-	-	-	-	-	-	-	-	-	725 (50)	725 (50)	468 (32)	275 (19)	180 (12)	114 (8)	
	36 (2.5)			-	-	-	-	-	-	-	-	-	-	-	725 (50)	428 (30)	281 (19)	179 (12)	
	44 (3)			-	-	-	-	-	-	-	-	-	-	-	-	581 (40)	382 (26)	243 (17)	
	51 (3.5)			-	-	-	-	-	-	-	-	-	-	-	-	725 (50)	480 (33)	306 (21)	
	58 (4)			-	-	-	-	-	-	-	-	-	-	-	-	-	584 (40)	373 (26)	

Do not exceed 60 psigg (4 bargg) air pressure to the actuator.

* For 2" valves with reduced port trims only.

The data above includes both equal percentage and linear shut off pressure.

Designs, materials, weights and performance ratings are approximate and subject to change without notice. Visit armstronginternational.com for up-to-date information.



Armstrong® Python® - 1500 Series Control Valves

Table 10 - 3, Cage Guided (Parabolic Pressure Balanced) Shut Off Pressure for Reverse Acting Actuator								
Actuator Model No.	Min. Air Supply to Actuator W/ Positioner	Spring Range	Diap. Area	Maximum Differential Pressure psig (barg) / Δ P / Shut Off Pressure				
				Trim Size				
				CV	30	50	85	110
	psig (barg)	psig (barg)	Inch ²	1 - 1/2"	2"	2 - 1/2"	3"	4"
174 20mm	20 (1.3)	3-15 (0.2 - 1)	27in ²	218 (15)	-	-	-	-
	23 (1.5)	6-18 (0.4 - 1.2)		725 (50)	-	-	-	-
	37 (2.5)	9-32 (0.6 - 2.2)		725 (50)	-	-	-	-
	43 (2.9)	16-38 (1.1 - 2.6)		725 (50)	-	-	-	-
348 20mm	20 (1.3)	3-15 (0.2 - 1)	54in ²	725 (50)	-	-	-	-
	23 (1.5)	6-18 (0.4 - 1.2)		725 (50)	-	-	-	-
348 30mm	20 (1.3)	3-15 (0.2 - 1)	54in ²	595 (41)	566 (39)	-	-	-
	23 (2.5)	6-18 (0.4 - 1.2)		725 (50)	725 (50)	-	-	-
	37 (2.5)	9-32 (0.6 - 2.2)		725 (50)	725 (50)	-	-	-
	43 (2.9)	16-38 (1.1 - 2.6)		725 (50)	725 (50)	-	-	-
348 40mm	20 (1.3)	3-15 (0.2 - 1)	54in ²	-	-	522 (36)	457 (32)	384 (26)
	23 (2.5)	6-18 (0.4 - 1.2)		-	-	725 (50)	725 (50)	725 (50)
	43 (2.9)	16-38 (1.1 - 2.6)		-	-	725 (50)	725 (50)	725 (50)
700 30mm	20 (1.3)	3-15 (0.2 - 1)	108in ²	725 * (50)	725 (50)	-	-	-
	23 (2.5)	6-18 (0.4 - 1.2)		725 * (50)	725 (50)	-	-	-
	43 (2.9)	16-38 (1.1 - 2.6)		725 * (50)	725 (50)	-	-	-
700 40mm	20 (1.3)	3-15 (0.2 - 1)	108in ²	-	-	725 (50)	725 (50)	725 (50)
	23 (2.5)	6-18 (0.4 - 1.2)		-	-	725 (50)	725 (50)	725 (50)
	43 (2.9)	16-38 (1.1 - 2.6)		-	-	725 (50)	725 (50)	725 (50)

* Indicates 2" valve with reduced port trim

Python® - 1500 Series Control Valves



Table 11 - 4, Cage Guided (Parabolic Pressure Balanced) Shut Off Pressure for Direct Acting Actuator								
Actuator Model No.	Min. Air Supply to Actuator W/ Positioner	Spring Range	Diap. Area	Maximum Differential Pressure psig (barg) / Δ P / Shut Off Pressure				
				Trim Size				
				CV	30	50	85	110
	psig (barg)	psig (barg)	Inch ²	1 - 1/2"	2"	2 - 1/2"	3"	4"
174 20mm	23 (1.5)	3-15 (0.2 - 1)	27in ²	536 (37)	-	-	-	-
	29 (2)			725 (50)	-	-	-	-
348 20mm	23 (1.5)	3-15 (0.2 - 1)	54in ²	725 (50)	-	-	-	-
348 30mm & 40mm	23 (1.5)	3-15 (0.2 - 1)	54in ²	725 (50)	725 (50)	725 (50)	725 (50)	710 (49)
	29 (2)			-	-	-	-	725 (50)

* Indicates 2" valve with reduced port trim



Armstrong® Python® - Pneumatic Actuated Model Identification

MODEL NUMBER

CV1500 – 2 150RF CTS 2 TR TEFL RA 3-15 348-30 SRD 4-20 17-4PH PPB EQ NA

Connection Size	
in	mm
½	15
¾	20
1	25
1-¼	32
1-½	40
2	50
2-½	65
3	80
4	100

Connection Type
150 RF
300 RF
NPT

Valve Material
CTS: ASTM A216
SS: CF8M

Trim Size	
in	mm
1/8 TR	3
5/32 TR	4
3/16 TR	5
1/4 TR	6
9/32 TR	7
7/16 TR	11
1/2 TR	16
3/4 TR	18
1 TR	24
1-1/4 TR	32
1-1/2 TR	38
2 TR	50
2-1/2 TR	65
3 TR	80
4 TR	100

Packing
TEFL: Teflon
GFL: Grafoil

Actuator Size and Stroke
172 -20: 172 cm ² Actuator/ 20mm Stroke
348-20: 348 cm ² Actuator/ 20mm Stroke
348-30: 348 cm ² Actuator/ 30mm Stroke
348-40: 348 cm ² Actuator/ 40mm Stroke
700-30: 700cm ² Actuator / 30mm Stroke
700-40: 700 cm ² Actuator/ 40mm Stroke

Positioners
NA-None
SRP: Foxboro Pneumatic
SRI: Foxboro I/P Analog
SRD: Foxboro Digital
SRDH: Foxboro Digital w/Hart
SRDF: Foxboro Digital w/Fieldbus
SRDEx: Foxboro Digital

Spring Range
3-15
6-18
9-32
16-38

Fail Position
RA: Reverse Acting
DA: Direct Acting

Positioner Set
NA-None
3-15 psig
3-9 psig
9-15 psig
4-20mA
4-12mA
12-20mA

Trim Type
PPB: Parabolic Pressure Balance
PU: Parabolic Unbalanced

Trim Characteristic
EQ: Equal Percentage
LIN: Linear

Trim Material
17-4 PH h900
STELL
PTFE Soft Seat

Accessories
NA: None
LSM: Limit Switch Mechanical
LSP: Limit Switch Proximity
FB: 4-20mA Feedback

Designs, materials, weights and performance ratings are approximate and subject to change without notice. Visit armstronginternational.com for up-to-date information.

Python® BEL– Belimo Electric Linear Actuator



For 24VAC/24VDC fail safe, proportional modulating control of the CV1500 in HVAC and hydronic systems.

Actuator sizing will be dictated by the valve size selection. All valve selections should be done in accordance with the flow parameters and system specifications. The actuator is mounted directly to the CV1500 bonnet by means of an innovative clamp and collar.

The actuator operates in response to a 2-10 VDC input signal, or with the addition of a 500 Ω resistor, a 4-20 mA input signal from an electric controller or positioner. A 2-10 VDC VDC feedback signal is provided for position indication.

Product Features:

- Power: 24VAC/VDC
- Fail Safe: 35 second run time
- Frequency: 50 or 60 Hz
- Pillar mechanical clamp collar connection
- Auto/Manual control
- Control Signal: 2-10V or 4-20mA
- Protection Class: Nema 2, IP54, UL enclosure type 2
- Shut Off: Up to 100psig on all sizes
- ½” – 1-1/2” Belimo SVKB24-SR
- 2” Belimo AVKB24-MFT



CV1500 BEL

Technical Data	
Flow Characteristic	Equal Percentage or Linear
Leakage	ANSI Class IV (Metal to Metal) ANSI Class VI (PTFE Soft Seat)
Rangeability	50:1
Voltage	24VAC/24VDC
Control Signal	2-10V / 4-20mA

List of Materials	
Valve Body	Carbon Steel A216 Gr. WCB
Bonnet	Stainless Steel CF8M
Valve/Valve Seat	17-4 PH h900 / Standard Stellite / Option PTFE Soft Seat / Option - 388F (198C) Max.
Valve Spindle	ANSI SS 431
Gland Packing	Carbon Filled V-Teflon (450°F (232°C) Max.)

For more information download Belimo Technical data SVKB24 or AVKB24-MFT

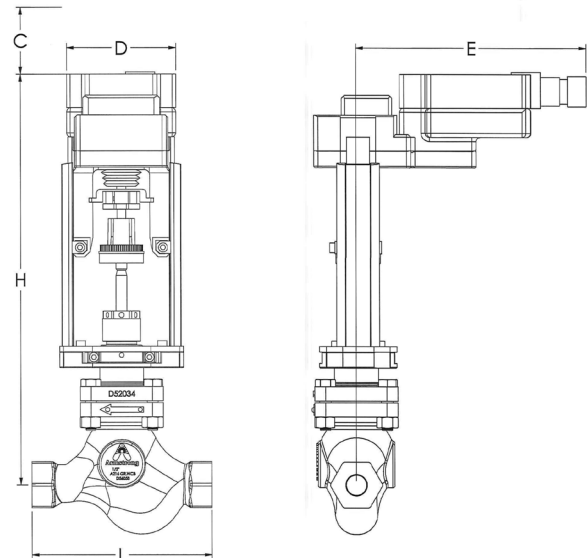

Dimensions and Weight - BEL1500 (Belimo) Electric Actuator																					
Size		Face-to-Face “L”						“C”		“D”		“E”		“H”		Weight					
		NPT		150#		300#										NPT		150#		300#	
in	mm	in	mm	in	mm	in	mm	in	mm	in	mm	in	mm	in	mm	lb	kg	lb	kg	lb	kg
1/2	15	6-1/2	165	7-1/4	184	7-1/2	190	4	102	4	102	8-1/4	210	14-3/4	375	13.1	28.9	13.6	30.0	14.9	32.8
3/4	20	6-1/2	165	7-1/4	184	7-5/8	194	4	102	4	102	8-1/4	210	14-3/4	375	13.1	28.9	14.6	32.2	17.0	37.5
1	25	7-3/4	197	7-1/4	184	7-3/4	197	4	102	4	102	8-1/4	210	14-3/4	375	17.6	38.8	19.6	43.2	22.6	49.8
1-1/4	32	9-1/4	235	8	203	8-1/2	216	4	102	4	102	8-1/4	210	15-3/4	400	21.6	47.6	22.8	50.3	27.2	60.0
1-1/2	40	9-1/4	235	8-3/4	222	9-1/4	235	4	102	4	102	8-1/4	210	15-3/4	400	22.6	49.8	25.6	56.4	32.1	70.8
2	50	10-1/2	267	10	254	10-1/2	267	4	102	5-1/2	140	10-1/4	260	19-3/4	502	43.8	96.6	48.8	107.6	54.6	120.4

Max shut off pressure is 100psig [6.89 barg] on all sizes

Designs, materials, weights and performance ratings are approximate and subject to change without notice. Visit armstronginternational.com for up-to-date information.



Armstrong® Python® - AEL Electric Linear Actuators

When accurate control of your steam or water application is desired and air is not available, the Python® AEL Electric Control Valve will deliver precise control. The electric version of the popular 1500 series control valve is built to out perform and deliver accurate control. The AEL Series Electric Control Valve is constructed and equipped with state of the art industrial materials combined with the standard 1500 series main valve.

Python® Series 1500
AEL Electric Actuator



Product Features:

- Power: 24V AC (120V AC or 240V AC available)
- Frequency 50 or 60 Hertz
- Terminal board connection
- Pillar mechanical connection
- Auto/Manual control
- Control signal 4-20 mA, 0-10 volts
- Protection class IP 67
- High thrust capabilities
- Electronic position control
- Metal internal gears
- Compact design
- Mounts to the standard 1500 Series valve body
- Actuators available for valves from 1/2" to 4"
- 135°F max. ambient temperature

Technical Data	
Flow Characteristics	Equal Percentage
Leakage	ANSI Class IV (Metal to Metal) ANSI Class VI (PTFE Soft Seat)
Rangeability	50:1
Voltage	24VAC, 120VAC and 240VAC Power Supply

List of Materials	
Valve Body	Carbon Steel A216 GR. WCB
Bonnet	Stainless Steel CF8M
Valve/Valve Seat	Stainless Steel 17-4 PH h900 / Standard Stellite / Option PTFE Soft Seat / Option - 388F (198C) Max.
Valve Stem	Stainless Steel 431
Gland Packing	Carbon Filled V-Teflon - Option 1 (450°F (232°C) max) Grafoil - Option 2 (800°F (427°C) max)
Yoke	Steel
Actuator Housing	Aluminum
Cage Material	ASTMA743 Gr CB30
Sealing Ring Material	Carbon Filled V-Teflon

Pressure Temperature Rating for Carbon Steel Valves		
Temp °F (°C)	Class 150 psig (barg)	Class 300 psig (barg)
100 (38)	285 (20)	740 (51)
200 (93)	260 (18)	675 (47)
300 (149)	230 (16)	655 (45)
400 (204)	200 (14)	635 (44)
500 (260)	170 (12)	600 (41)
600 (316)	140 (10)	550 (38)
650 (343)	125 (9)	535 (37)
700 (371)	110 (8)	535 (37)
750 (399)	95 (7)	505 (35)
800 (427)	80 (6)	410 (28)

Pressure Temperature Rating for CF8M Valves		
Temp °F (°C)	Class 150 psig (barg)	Class 300 psig (barg)
up to 100 (38)	275 (19)	720 (50)
200 (93)	235 (16)	620 (42)
300 (149)	215 (15)	560 (39)
400 (204)	195 (14)	515 (36)
500 (260)	170 (12)	480 (33)
600 (316)	140 (10)	450 (32)
650 (343)	125 (9)	445 (31)
700 (371)	110 (8)	430 (30)

Designs, materials, weights and performance ratings are approximate and subject to change without notice. Visit armstronginternational.com for up-to-date information.

Table 15-1. CV1500AEL							
Size of Valve		NPT - 150# Flg and 300# Flg					
in	mm	Max load thrust [N] modulating duty	Max load thrust [N] ON/OFF	Speed [mm/min]	Modulating Model	ON/OFF Model	Stroke [mm]
1/2	15	1900	1600	24	AEL1430	AEL1490	20
3/4	20	1900	1600	24	AEL1430	AEL1490	20
1	25	1900	1600	24	AEL1430	AEL1490	20
1-1/4	32	4600	4000	48	AEL1438	AEL1498	20
1-1/2	40	4600	4000	48	AEL1438	AEL1498	20
2	50	7200	6300	48	AEL1438	AEL1498	30
2-1/2	65	7200	6300	48	AEL1438	AEL1498	40
3	80	7200	6300	48	AEL1438	AEL1498	40
4	100	7200	6300	48	AEL1438	AEL1498	40

Table 15-2. Contoured Top Guided Parabolic Unbalanced Max. Operating Pressure for Modulating Electric Actuators - psig (barg)																	
Actuators	Thrust kg	Cv Value	0.12	0.3	0.5	0.7	1.2	3	5	9	13	21	30	50	80	110	185
			Trim size	1/8	5/32	3/16	1/4	9/32	7/16	1/2	3/4	1	1-1/4	1-1/2	2	2-1/2	3
AEL1430	130	psig	725	725	725	725	725	725	725	725	499	-	-	-	-	-	-
		barg	50	50	50	50	50	50	50	50	50	34	-	-	-	-	-
AEL1438	408	psig	-	-	-	-	-	-	-	-	-	716	506	-	-	-	-
		barg	-	-	-	-	-	-	-	-	-	49	35	-	-	-	-
AEL1438	408	psig	-	-	-	-	-	-	-	-	-	-	-	463	271	178	129
		barg	-	-	-	-	-	-	-	-	-	-	-	32	19	12	9

Note: may be derated depending on flange rating and type

Table 15-3. Cage Guided Parabolic Pressure Balanced Max. Shut Off Pressure for Modulating Electric Actuators - psig (barg)							
Actuators	Thrust kg	Cv Value	30	50	80	110	185
			Trim size	1 1/2	2	2 1/2	3
AEL1438	469	psig	725	-	-	-	-
		barg	50	-	-	-	-
AEL1438	734	psig	-	725	725	725	725
		barg	-	50	50	50	50

Note: may be derated depending on flange rating and type

Table 15-4. Contoured Top Guided Parabolic Unbalanced Max. Shut Off Pressure for ON/OFF Electric Actuators - psig (barg)																	
Actuators	Thrust kg	Cv Value	0.12	0.3	0.5	0.7	1.2	3	5	9	13	21	30	50	80	110	185
			Trim size	1/8	5/32	3/16	1/4	9/32	7/16	1/2	3/4	1	1-1/4	1-1/2	2	2-1/2	3
AEL1490	163	psig	725	725	725	725	725	725	725	725	595	-	-	-	-	-	-
		barg	50	50	50	50	50	50	50	50	41	-	-	-	-	-	-
AEL1498	408	psig	-	-	-	-	-	-	-	-	-	725	584	-	-	-	-
		barg	-	-	-	-	-	-	-	-	-	50	40	-	-	-	-
AEL1498	642	psig	-	-	-	-	-	-	-	-	-	-	-	531	312	203	131
		barg	-	-	-	-	-	-	-	-	-	-	-	37	22	14	9

Note: may be derated depending on flange rating and type



Armstrong® Python® - AEL Electric Linear Actuators

Dimensions and Weights																			
Size		Face-to-Face "L"						"C"		"D"		"H"		Weight					
in	mm	NPT		150#		300#								NPT		150#		300#	
		in	mm	in	mm	in	mm	in	mm	in	mm	in	mm	lb	kg	lb	kg	lb	kg
1/2	15	6-1/2	165	7-1/4	184	7-1/2	190	6-1/4	160	3-3/8	87	19-3/4	502	21	10	21	10	21	10
3/4	20	6-1/2	165	7-1/4	184	7-5/8	194	6-1/4	160	3-3/8	87	19-3/4	502	21	10	22	10	22	10
1	25	7-3/4	197	7-1/4	184	7-3/4	197	6-1/4	160	3-3/8	87	19-3/4	502	25	12	27	13	30	14
1-1/4	32	9-1/4	235	8	203	8-1/2	216	6-1/4	160	3-3/8	87	21-1/2	546	36	16	37	17	41	19
1-1/2	40	9-1/4	235	8-3/4	222	9-1/4	235	6-1/4	160	3-3/8	87	21-1/2	546	37	17	40	18	46	21
2	50	10-1/2	267	10	254	10-1/2	267	6-1/4	160	3-3/8	87	21-5/8	548	53	24	58	26	63	29
2-1/2	65	-	-	10-7/8	276	11-1/2	292	6-1/4	160	3-3/8	87	24-1/4	616	-	-	80	36	85	39
3	80	-	-	11-3/4	298	12-1/2	318	6-1/4	160	3-3/8	87	24-9/16	624	-	-	98	44	106	48
4	100	-	-	13-7/8	352	14-1/2	368	6-1/4	160	3-3/8	87	25-9/16	650	-	-	147	67	164	74

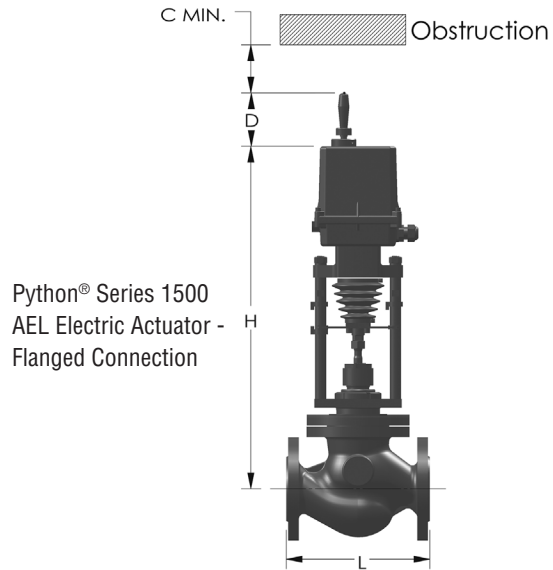
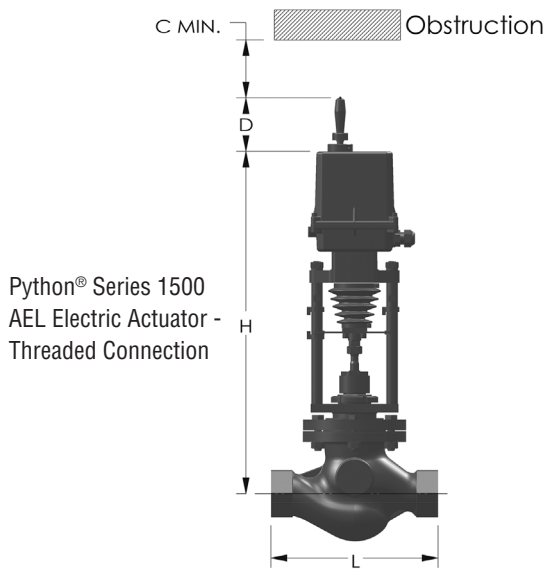

Designs, materials, weights and performance ratings are approximate and subject to change without notice. Visit armstronginternational.com for up-to-date information.

MODEL NUMBER

AEL BEL - 2 150RF CTS 2 TR TEFL 4-20 220V 4-20 17-4PH PPB EQ

Connection Size	
in	mm
½	15
¾	20
1	25
1-¼	32
1-½	40
2	50
2-½	65
3	80
4	100

Connection Type
150 RF
300 RF
NPT

Valve Material
CTS: ASTM A216
SS: CF8M

Trim Size	
in	mm
1/8 TR	3
5/32 TR	4
3/16 TR	5
1/4 TR	6
9/32 TR	7
7/16 TR	11
1/2 TR	16
3/4 TR	18
1 TR	24
1-1/4 TR	32
1-1/2 TR	38
2 TR	50
2-½ TR	65
3 TR	80
4 TR	100

Packing
TEFL: Teflon
GFL: Grafoil

Control Signal
4-20 mA
0-10 V
2-10 V
ON-OFF

Power
24VAC
110VAC
240VAC

Feedback
4-20: 4-20 mA
100: 100 Ohm
: No Feedback

Trim Type
PU: Parabolic Unbalanced
PPB: Parabolic Pressure Balance

Trim Characteristic
EQ: Equal Percentage
LIN: Linear

Trim Material
17-4 PH h900
STELL
PTFE Soft Seat

Designs, materials, weights and performance ratings are approximate and subject to change without notice. Visit armstronginternational.com for up-to-date information.



Armstrong® Python® - 1500 Series Control Valves

Valve Sizing

To determine the size of valve you need, calculate the required Cv value for your application. Once you have calculated the required Cv, refer to the valve Cv charts on page 4 to determine the size and trim of valve. Globe style control valves have the best control in the midrange of the valve's capacity. It is best to pick a valve so the calculated Cv is between 15% and 85% of the valve's maximum Cv. See the formulas below for steam and water applications. Consult factory for other types of fluids.

For Saturated Steam Service

Subcritical Flow

When $\Delta P < 0.81(P_{1/2})$

$$C_v = \frac{W}{2.1\sqrt{\Delta P(P_{1A}+P_{2A})}}$$

Critical Flow

When $\Delta P \geq 0.81(P_{1/2})$

$$C_v = \frac{W}{1.633(P_{1A})}$$

For Liquid Service

$$C_v = \frac{(GPM)\sqrt{G}}{\sqrt{\Delta P}}$$

Cv = Valve flow coefficient

W = Maximum flow capacity of steam, lbs/hr

P_{1A} = Inlet Pressure, psiga (psig + 14.7)

P_{2A} = Outlet Pressure, psiga (psig + 14.7)

ΔP = Pressure drop (P₁ - P₂) psig

GPM = Maximum flow capacity of Liquid, GPM

G = Specific Gravity

Actuator Sizing

To determine the required actuator, you need to determine the differential pressure (shut off pressure). The shut off pressure for a pressure reduction application is the pressure difference between P₁ and P₂. The shut off pressure for a temperature control application is the P₁ pressure.

Once you have calculated your shut off pressure, select the actuator model and spring setting range that exceeds your calculated shutoff pressure with the trim size previously selected. Select reverse acting for air to open (fail close) applications or direct acting for air to close (fail open) applications.

Make sure the required air pressure is available for the spring range selected.

Sizing Example 1:

Fluid: Saturated Steam

Application: Temperature Control

P₁: 125 psig

Flow: 1750 lbs/hr

Actuator: Air to open (Fail Close)

Solution:

Since this is a temperature control application and we do not know the P₂ pressure, we will size the valve with a 30% pressure drop. We need to use the subcritical flow formula.

$$C_v = \frac{1750}{2.1\sqrt{(37)((125+14.7)+(88+14.7))}} = 8.8$$

Refer to the Cv charts on Page 4. Select a 1" Contoured top guided with full port trim. The 1" is chosen over the 3/4" because the valve will control best between 15% - 85% of maximum valve capacity. The 3/4" valve would be operating at 98% of valve capacity.

These formulas are derived from the ANSI/ISA-75.01.01 standard to allow for easy daily use. These simplified formulas contain assumptions on some parameters and will always give a conservative sizing.

For detailed sizing using the ANSI/ISA-75.01.01 approach, use Armstrong selection software.



INTELLIGENT SOLUTIONS IN STEAM, AIR AND HOT WATER

Armstrong International

North America • Latin America • India • Europe / Middle East / Africa • China • Pacific Rim

armstronginternational.com